



JRSGS®

ADD: 58 Shengfa Road, Lucheng Light Industrial Zone,
Wenzhou, China.

TEL: 0086-577-86479618 86478618 86480618

FAX: 0086-577-86471288 86481618 P.C: 325019

<http://www.jinruirigging.com> E-mail: rigging@luchengrigging.com

浙江金瑞五金索具有限公司
ZHEJIANG JINRUI HARDWARE RIGGING CO.,LTD.

JRSGS®

JINRUI
guarantees safety
and harmony



公司简介 Company Profile

www.jinruirigging.com

浙江金瑞五金索具有限公司创立于1992年，前身是温州市鹿城索具有限公司，位于风景优美的成浦江畔，省级开发区鹿城轻工产业园区盛发路58号，是一家集研发、生产、销售为一体的并拥有自营出口权的企业，建筑面积23000平方米，现有员工300多人，其中各类专业技术人员50多人。公司在发展过程中不断投入研发资金，成立研发团队，成功研制出不锈钢弹簧钩及快速连接环自动生产流水线，并荣获国家发明专利。该研发项目使产品拉力及各项性能达到国际标准。公司为了保证产品的质量还配备了各种检测设备：数控拉力测试机、不锈钢光谱分析仪(材质)、盐雾试验机、锌层厚度测试仪等。

公司本着“质量第一，客户至上”的理念，以及金瑞人开拓进取的精神，产品弹簧钩、连接环、拉具、卸扣等远销欧美、澳洲、东南亚及台湾等国家和地区，深受广大客户的信赖和好评。

“精益求精”是金瑞企业永不停止的追求，不断引进高级管理人才，不断完善企业管理，2005年通过ISO9001（2000版）质量体系认证，2017年升级通过SGS/ISO9001（2015年版）质量体系认证；公司连续多年被评为省工商AA级重合同守信用企业、省级科技型企业、温州市科技（创新）型企业、温州市首批百家诚信企业、农业银行企业、鹿城工业百强企业、鹿城国税纳税50强企业。

公司以“不求最大，力争最优”的经营方针，以“顾客满意”为质量方针；以“爱护环境、回报社会”为社会责任；竭诚为各界新老客户提供优质价廉的产品，愿与广大客户携手共创美好的明天！

Zhejiang Jinrui Hardware Rigging Co., Ltd, previously named as Wenzhou Lucheng Rigging Co., Ltd, was established in 1992. The company is located at 58 Shengfa Road, Lucheng Light Industrial Zone, Wenzhou City, Zhejiang Province which is next to the beautiful Shupu River.

Ever since its establishment, the company has been progressing constantly and continuously, developing into a company with more than three hundred staff, including more than fifty professional technicians. Covering an area of 23,000 square meters (247,000 square feet), the company has been specialized in researching, developing, producing and marketing as well, and has been entitled to independent export privileges.

During the development process, the company invested funds, set up teams of research & development, and successfully developed automatic production lines for stainless steel snap hook and quick link, and was rewarded with the national invention patent. This project ensures that the tension and performance of these products can reach the international standard. In order to ensure perfect quality, the company equips various testing equipment including CNC pulling strength testing machines, stainless steel spectrum characteristic testing equipment, salt spray test enginery, zinc thickness tester etc.

We pursue the philosophy of “quality first and customer-oriented”, and follow our own pioneering spirits. Our most popular products include snap hook, quick link, rigging screw, shackle etc, which have won high praise and trust from our customers from Europe, Australia, Southeast Asia and the regions such as Taiwan.

The company pursues perfection through various methods such as constantly improving product quality, introducing quality management and recruiting qualified professionals. The company was rewarded ISO9001 (2000 edition) in 2005, as well as SGS/ISO9001 (2015 edition) in 2017. For many years, our company has been rated as a provincial AA grade enterprise, provincial science & tech enterprise, Wenzhou technological innovation enterprise, Top 100 most reliable and trustworthy enterprise, as well as an AAA credit rated enterprise and local Top 50 tax generating enterprise.

The marketing policy of our company is to strive for the best and our quality goal is to maximize the customer satisfaction. We devote ourselves to taking social responsibilities by making contribution to environment and society. By providing products with the highest quality and competitive price for customers, we sure we will create a brilliant future for mutual benefit.



ZHEJIANG JINRUI HARDWARE RIGGING CO.,LTD



JINRUI HARDWARE RIGGING



FMP10-40 系列涂镀层测厚仪
FMP10-40 Series Coating Thickness Measuring Instruments



INNOV-X 手持型X射线荧光光谱仪
Innov-X Handheld xrf alloy analyzer

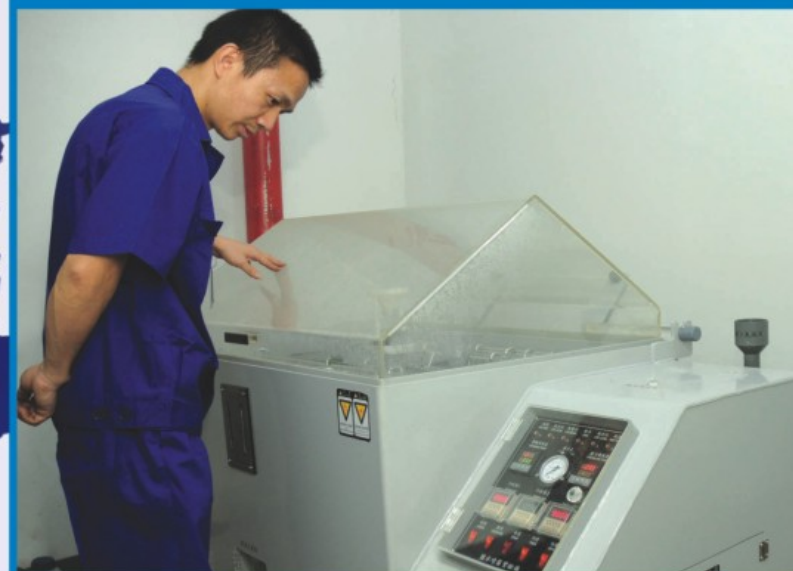















MT-90B 精密型盐水喷雾试验机
Salt Spray Test Machine MT-90B



WDW-200E 微机控制电子式万能试验机
Electronic Universal Testing Machine WDW-200E

Contents

CARABINER SERIES		01-11
SHACKLE SERIES		12-13
TURNBUCKLE / SCREW JAW SWAGE TERMINAL SERIES		14-17
CLIP/THIMBLE / SWIVEL SERIES		18-20
SNAP HOOK/ QUICK LINK SERIES		21-26
EYE NUT/BOLT/STRAP PLATE SERIES		27-31
CASTING HOOK SERIES		32-34
RING/HOOKS/SWIVELING/HAIR PIN LYNCH PINS SERIES		35-43
ALUMINUM SNAP HOOK SERIES		44-46
FORGED HOOK		47
ZINC ALLOY DIE CAST SERIES		48-57
BRONZE CASTING SNAPS AND BUCKLE SERIES		58-64
WIRE ROPE SERIES		65-68
CHAIN SERIES		69

SGM7101

Material: Aluminum alloy, 7075
 Breaking load(KN): $\pm 24 \pm 7\%$
 Net weight: 49g
 Colors: Anodized



New!

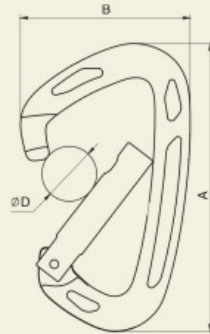

A	B	D	d	W
mm	mm	mm	mm	mm
100	59	19	/	12.1

SGM7103TN

Material: Aluminum alloy, 7075/6061
 Breaking load(KN): $\pm 25 \pm 7\%$
 Net weight: 89g
 Colors: Anodized
 Breaking load for 6061: 16KN



New!

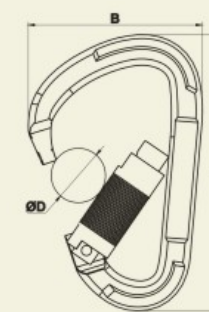

A	B	D	d	W
mm	mm	mm	mm	mm
115	72.5	22	/	11.4

SGM7101A

Material: Aluminum alloy, 7075
 Breaking load(KN): $\pm 24 \pm 7\%$
 Net weight: 49g
 Colors: Anodized



New!

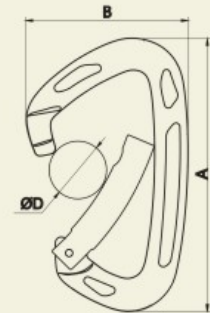

A	B	D	d	W
mm	mm	mm	mm	mm
100	59	21	/	12.1

SGM7104B

Material: Aluminum alloy, 7075
 Breaking load(KN): $\pm 25 \pm 7\%$
 Net weight: 62g
 Colors: Anodized



New!

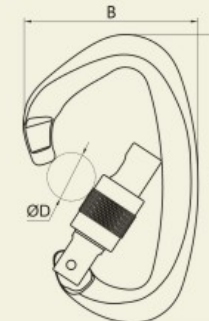

A	B	D	d	W
mm	mm	mm	mm	mm
100	60	16	/	12.5

SGM7101B

Material: Aluminum alloy, 7075
 Breaking load(KN): $\pm 24 \pm 7\%$
 Net weight: 52g
 Colors: Anodized



New!

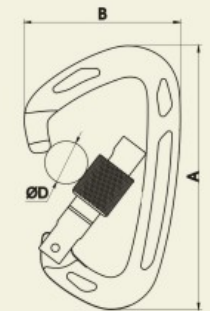

A	B	D	d	W
mm	mm	mm	mm	mm
100	59	16	/	12.1

SGM7105B

Material: Aluminum alloy, 7075
 Breaking load(KN): $\pm 25 \pm 8\%$
 Net weight: 78g
 Colors: Anodized



New!

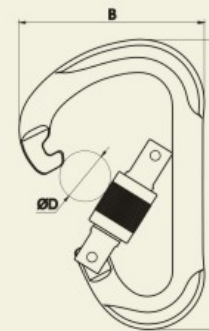

A	B	D	d	W
mm	mm	mm	mm	mm
116	75	21	/	11.8

SGM7101TN

Material: Aluminum alloy, 7075
 Breaking load(KN): $\pm 24 \pm 7\%$
 Net weight: 57g
 Colors: Anodized



New!

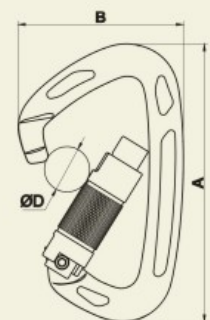

A	B	D	d	W
mm	mm	mm	mm	mm
100	59	16	/	12.1

SGM7106

Material: Aluminum alloy, 7075
 Breaking load(KN): $\pm 22 \pm 7\%$
 Net weight: 44g
 Colors: Anodized



New!



A	B	D	d	W
mm	mm	mm	mm	mm
100	58	22	/	11.1

SGM7106A

Material: Aluminum alloy, 7075
 Breaking load(KN): --22 ± 7%
 Net weight: 44g
 Colors: Anodized



New!

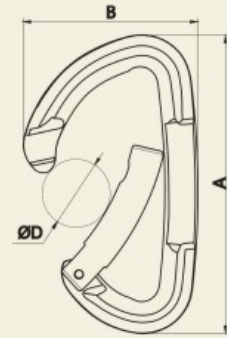

A	B	D	d	W
mm	mm	mm	mm	mm
100	58	22	/	11.1

SGM7108C

Material: Aluminum alloy, 7075
 Breaking load(KN): --25 ± 8%
 Net weight: 66g
 Colors: Anodized



New!

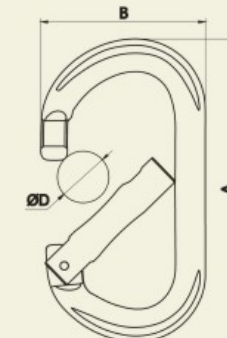

A	B	D	d	W
mm	mm	mm	mm	mm
111	60	22	/	11

SGM7107B

Material: Aluminum alloy, 7075
 Breaking load(KN): --25 ± 9%
 Net weight: 84g
 Colors: Anodized



New!

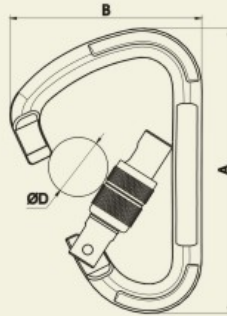

A	B	D	d	W
mm	mm	mm	mm	mm
111	75	22	/	11.5

SGM7108B

Material: Aluminum alloy, 7075
 Breaking load(KN): --25 ± 8%
 Net weight: 73g
 Colors: Anodized



New!

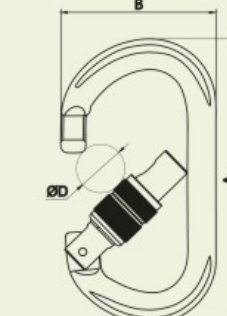

A	B	D	d	W
mm	mm	mm	mm	mm
111	60	19	/	11

SGM7107TN

Material: Aluminum alloy, 7075
 Breaking load(KN): --25 ± 9%
 Net weight: 87g
 Colors: Anodized



New!

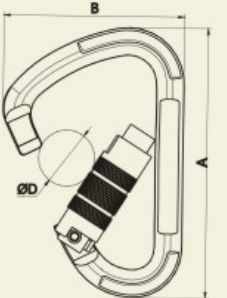

A	B	D	d	W
mm	mm	mm	mm	mm
111	75	22	/	11.5

SGM7108TN

Material: Aluminum alloy, 7075
 Breaking load(KN): --25 ± 8%
 Net weight: 79g
 Colors: Anodized



New!

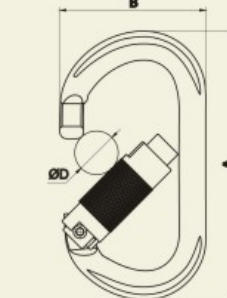

A	B	D	d	W
mm	mm	mm	mm	mm
111	60	19	/	11

SGM7108

Material: Aluminum alloy, 7075
 Breaking load(KN): --25 ± 8%
 Net weight: 67g
 Colors: Anodized



New!

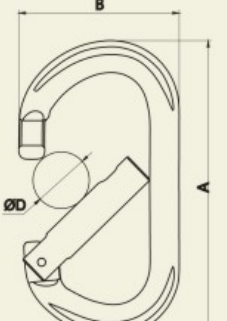

A	B	D	d	W
mm	mm	mm	mm	mm
111	60	22	/	11

SGM7109B

Material: Aluminum alloy, 7075
 Breaking load(KN): --23 ± 7%
 Net weight: 67g
 Colors: Anodized



New!



A	B	D	d	W
mm	mm	mm	mm	mm
106	66.5	20	/	11.5

SGM7109TN

Material: Aluminum alloy, 7075
 Breaking load(KN): $\pm 23 \pm 7\%$
 Net weight: 77g
 Colors: Anodized

New!

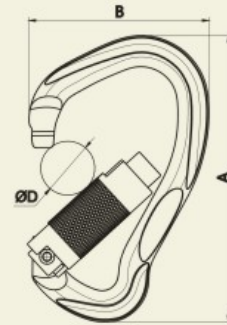
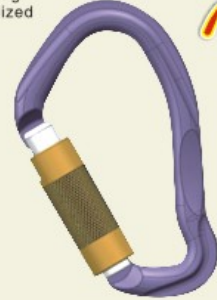

A	B	D	d	W
mm	mm	mm	mm	mm
106	66.5	20	/	11.5

SGM7801S

Material: Aluminum alloy, 7075/6061
 Breaking load(KN): 12KN/5KN
 Net weight: 22g
 Colors: Anodized

New!

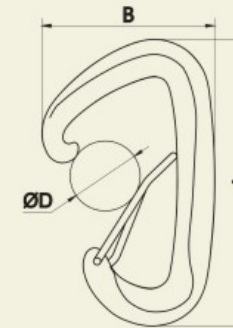

A	B	D	d	W
mm	mm	mm	mm	mm
111	60	22	/	11

SGM7801

Material: Aluminum alloy, 7075/6061
 Breaking load(KN): 12KN/5KN
 Net weight: 25g
 Colors: Anodized

New!

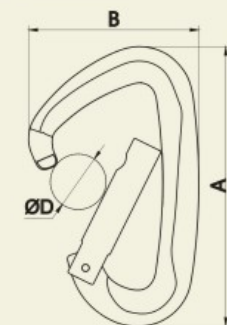

A	B	D	d	W
mm	mm	mm	mm	mm
80	48	16	/	10

SGM7802

Material: Aluminum alloy, 7075/6061
 Breaking load(KN): 12KN/5KN
 Net weight: 23g
 Colors: Anodized

New!

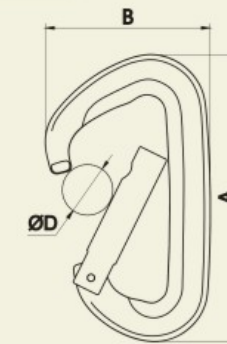

A	B	D	d	W
mm	mm	mm	mm	mm
81	48	16	/	11

SGM7801A

Material: Aluminum alloy, 7075/6061
 Breaking load(KN): 12KN/5KN
 Net weight: 25g
 Colors: Anodized

New!

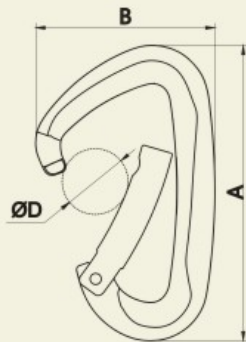

A	B	D	d	W
mm	mm	mm	mm	mm
80	48	17	/	10

SGM7802A

Material: Aluminum alloy, 7075/6061
 Breaking load(KN): 12KN/5KN
 Net weight: 23g
 Colors: Anodized

New!



A	B	D	d	W
mm	mm	mm	mm	mm
81	48	17	/	11

SGM7801B

Material: Aluminum alloy, 7075/6061
 Breaking load(KN): 12KN/5KN
 Net weight: 28g
 Colors: Anodized

New!

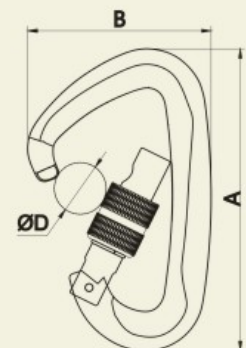

A	B	D	d	W
mm	mm	mm	mm	mm
80	48	13	/	10

SGM7802B

Material: Aluminum alloy, 7075/6061
 Breaking load(KN): 12KN/5KN
 Net weight: 26g
 Colors: Anodized

New!

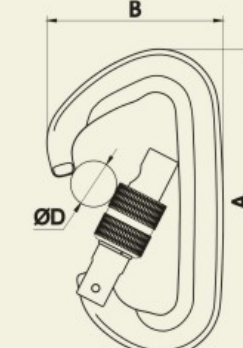

A	B	D	d	W
mm	mm	mm	mm	mm
81	48	13	/	11

SGM7802S

Material: Aluminum alloy, 7075/6061
 Breaking load(KN): 12KN/5KN
 Net weight: 20g
 Colors: Anodized

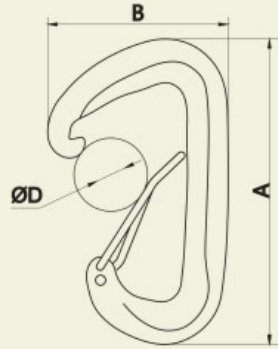

A	B	D	d	W
mm	mm	mm	mm	mm
81	48	20	/	11

SGM7803S

Material: Aluminum alloy, 7075/6061
 Breaking load(KN): 12KN/5KN
 Net weight: 3g
 Colors: Anodized

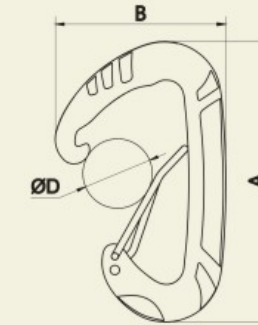

A	B	D	d	W
mm	mm	mm	mm	mm
81	48	20	/	10.5

SGM7803

Material: Aluminum alloy, 7075/6061
 Breaking load(KN): 12KN/5KN
 Net weight: 26g
 Colors: Anodized

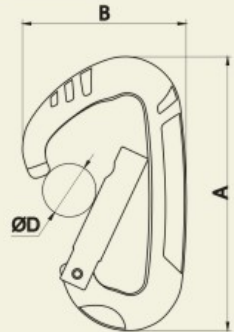

A	B	D	d	W
mm	mm	mm	mm	mm
81	48	16	/	10.5

SGM7803D1

Material: Aluminum alloy, 7075
 Breaking load(KN): 4KN
 Net weight: 24g
 Colors: Anodized

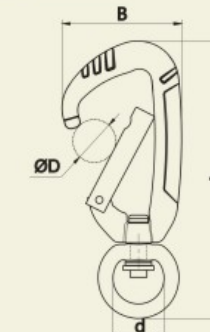

A	B	D	d	W
mm	mm	mm	mm	mm
89	38	11	16	8.6

SGM7803A

Material: Aluminum alloy, 7075/6061
 Breaking load(KN): 12KN/5KN
 Net weight: 26g
 Colors: Anodized

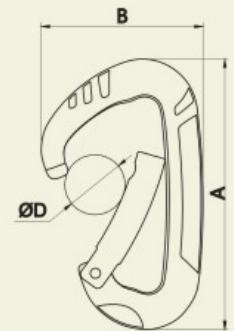

A	B	D	d	W
mm	mm	mm	mm	mm
80	48	17	/	10

SGM7803D2

Material: Aluminum alloy, 7075
 Breaking load(KN): 4KN
 Net weight: 24g
 Colors: Anodized

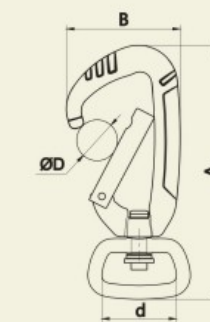

A	B	D	d	W
mm	mm	mm	mm	mm
89	38	11	25	8.6

SGM7803B

Material: Aluminum alloy, 7075/6061
 Breaking load(KN): 12KN/5KN
 Net weight: 29g
 Colors: Anodized

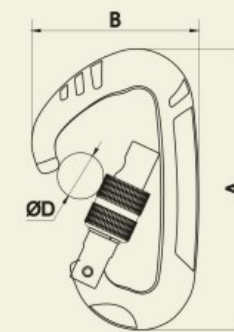

A	B	D	d	W
mm	mm	mm	mm	mm
81	48	13	/	10.5

SGM7803D3

Material: Aluminum alloy, 7075
 Breaking load(KN): 4KN
 Net weight: 24g
 Colors: Anodized

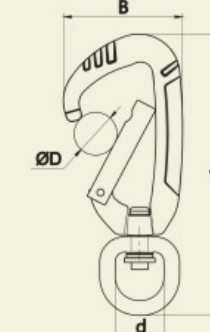

A	B	D	d	W
mm	mm	mm	mm	mm
89	38	11	15.5	8.6

SGM7803D4

Material: Aluminum alloy, 7075
 Breaking load(KN): 4KN
 Net weight: 24g
 Colors: Anodized



New!

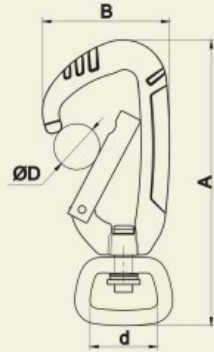

A	B	D	d	W
mm	mm	mm	mm	mm
89	38	11	20	8.6

SGM7803D4TN

Material: Aluminum alloy, 7075
 Breaking load(KN): 4KN
 Net weight: 24g
 Colors: Anodized



New!

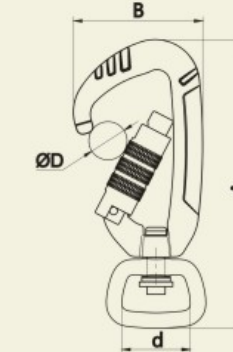

A	B	D	d	W
mm	mm	mm	mm	mm
89	38	11	20	8.6

SGM7803D1TN

Material: Aluminum alloy, 7075
 Breaking load(KN): 4KN
 Net weight: 24g
 Colors: Anodized



New!

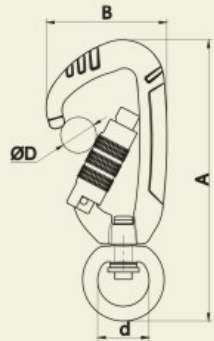

A	B	D	d	W
mm	mm	mm	mm	mm
89	38	11	16	8.6

SGM7804S

Material: Aluminum alloy, 7075/6061
 Breaking load(KN): 12KN/5KN
 Net weight: 23g
 Colors: Anodized



New!

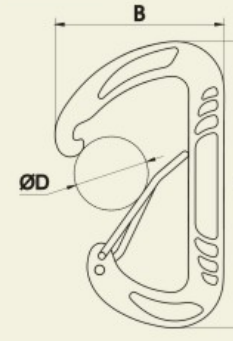

A	B	D	d	W
mm	mm	mm	mm	mm
80	47	20	/	10

SGM7803D2TN

Material: Aluminum alloy, 7075
 Breaking load(KN): 4KN
 Net weight: 24g
 Colors: Anodized



New!

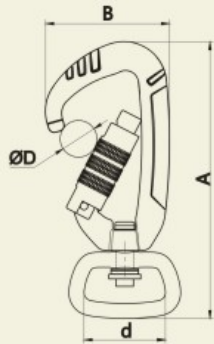

A	B	D	d	W
mm	mm	mm	mm	mm
89	38	11	25	8.6

SGM7806S

Material: Aluminum alloy, 7075/6061
 Breaking load(KN): 12KN/5KN
 Net weight: 20g
 Colors: Anodized



New!



A	B	D	d	W
mm	mm	mm	mm	mm
80	46	21	/	9

SGM7803D3TN

Material: Aluminum alloy, 7075
 Breaking load(KN): 4KN
 Net weight: 24g
 Colors: Anodized



New!

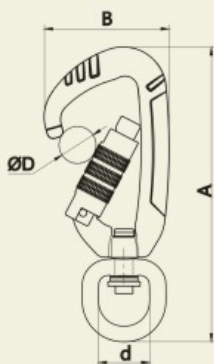

A	B	D	d	W
mm	mm	mm	mm	mm
89	38	11	15.5	8.6

8901

Material: Aluminum alloy, 7075
 Breaking load: Static strength 20KN, Dynamic strength 10KN
 Net weight: 74g
 Colors: Anodized



New!

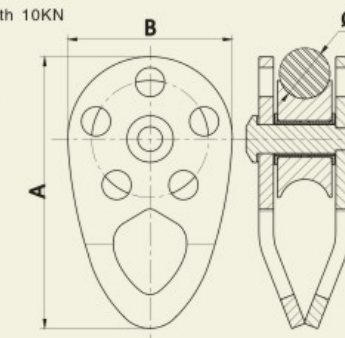

A	B	D	d	W
mm	mm	mm	mm	mm
74	45	≤13	/	/

SGM7805A



New!

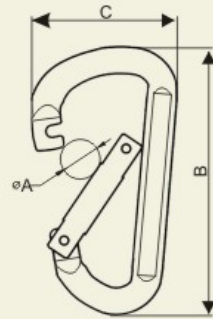

A	B	C
mm	mm	mm
14.6	80	43

SGM7805C



New!

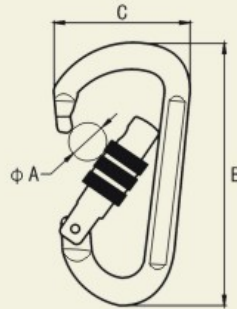

A	B	C
mm	mm	mm
14.6	80	43

SGM7112B



New!

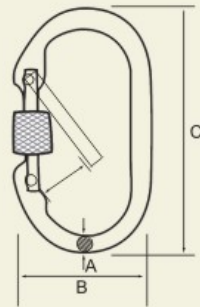

A	B	C
mm	mm	mm
10	55	105

SGM7112



New!

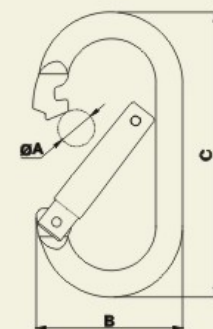

A	B	C
mm	mm	mm
10	54	100

EUROPEAN TYPE DEE SHACKLE

STAINLESS STEEL AISI316
STAINLESS STEEL AISI304

SGM0001

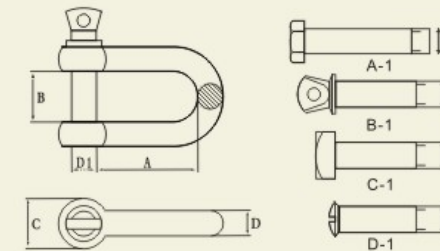

D	A	B	C	D1
mm	mm	mm	mm	mm
4	14	8	8	4
5	17	10	10	5
6	21	12	12	6
8	28	16	16	8
10	35	20	20	10
12	42	24	24	12
14	48	28	28	14
16	56	32	32	16
18	63	36	36	18
20	70	40	40	20
22	77	44	44	22
25	87	50	50	25

EUROPEAN TYPE BOW SHACKLE

STAINLESS STEEL AISI316
STAINLESS STEEL AISI304

SGM0002

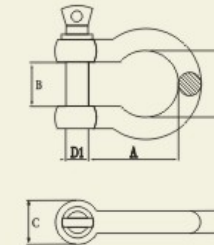

D	A	B	C	D1	F
mm	mm	mm	mm	mm	mm
4	16	8	8	4	12
5	20	10	10	5	15
6	24	12	12	6	18
8	32	16	16	8	24
10	40	20	20	10	30
12	48	24	24	12	36
14	56	28	28	14	42
16	64	32	32	16	48
18	72	36	36	18	54
20	80	40	40	20	60
22	88	44	44	22	66
25	100	50	50	25	75

LONG DEE SHACKLE

STAINLESS STEEL AISI316
STAINLESS STEEL AISI304

SGM0003

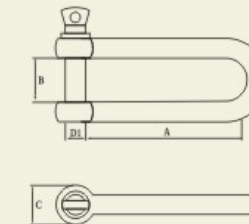

D	A	B	C	D1
mm	mm	mm	mm	mm
4	30	8	8	4
5	37	10	10	5
6	45	12	12	6
8	60	16	16	8
10	75	20	20	10
12	90	24	24	12
14	105	28	28	14
16	120	32	32	16

TWIST SHACKLE

STAINLESS STEEL AISI316
STAINLESS STEEL AISI304

SGM0004

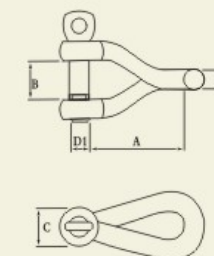

D	A	B	C	D1
mm	mm	mm	mm	mm
4	23	8	8	4
5	28	10	10	5
6	33	12	12	6
8	44	16	16	8
10	55	20	20	10
12	66	25	25	12

US TYPE ANCHOR SHACKLE

STAINLESS STEEL AISI316
STAINLESS STEEL AISI304
SGM0005

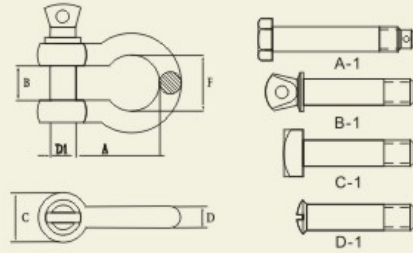

D	A	B	C	D1	F
mm	mm	mm	mm	mm	mm
3/16	22	9.5	14	1/4	15
1/4	28	12	15.5	5/16	20
5/16	31	13	19	3/8	21
3/8	36	16	23	7/16	26
7/16	42	18	27	1/2	29
1/2	48	21	30	5/8	33
5/8	60	27	38	3/4	43
3/4	71	32	46	7/8	51
7/8	84	36	53	1	58
1	95	43	60	1 1/8	68

US TYPE DEE SHACKLE

STAINLESS STEEL AISI316
STAINLESS STEEL AISI304
SGM0006

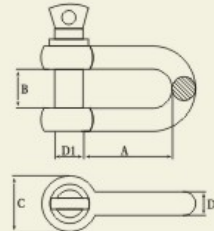

D	A	B	C	D1
mm	mm	mm	mm	mm
3/16		9.5	14.1	1/4
1/4		12	15.5	5/16
5/16		13	19	3/8
3/8		16	23	7/16
7/16	42	18	27	1/2
1/2		21	30	5/8
5/8		27	38	3/4
3/4	71	32	46	7/8
7/8	84	36	53	1
1	95	43	60	1 1/8

JIS TYPE DEE SHACKLE

STAINLESS STEEL AISI316
STAINLESS STEEL AISI304
SGM0007

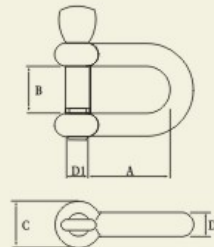

D	A	B	C	D1
mm	mm	mm	mm	mm
4	14	8	8	4
5	18	10	10	5
6	21	12	12	6
8	28	16	16	8
10	35	20	20	10
12	46	26	24	12
16	56	32	32	16
18	63	36	36	18
20	70	40	40	20
22	77	44	44	22
25	88	50	50	25

JIS TYPE BOW SHACKLE

STAINLESS STEEL AISI316
STAINLESS STEEL AISI304
SGM0008

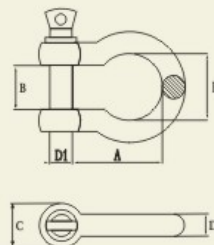

D	A	B	C	D1	F
mm	mm	mm	mm	mm	mm
4	18	8	8	4	14
5	22	10	10	5	17
6	27	13	12	6	21
8	37	16	16	8	28
10	46	19	20	10	35
12	54	25	24	12	42
16	74	32	32	16	56

TURNBUCKLE DIN 1480

STAINLESS STEEL AISI316
STAINLESS STEEL AISI304
STEEL ELECTRIC GALVANIZED
STEEL SELF COLOR
SGM0015

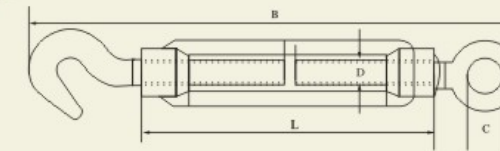
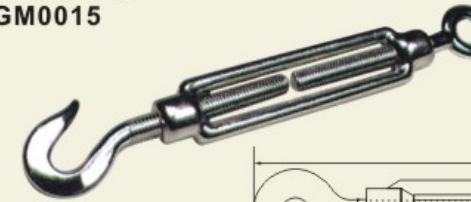

1.HOOK/EYE
2.HOOK/HOOK
3.EYE/EYE.

SIZE(D)	L	B	C
mm	mm	mm	mm
M5	70	120	8
M6	110	172-252	9
M8	110	182-257	10
M10	125	213-298	14
M12	125	238-318	16
M14	140	263-353	18
M16	170	320-430	22
M20	200	367-497	24

TURNBUCKLE EUROPEAN TYPE

STAINLESS STEEL AISI316
STAINLESS STEEL AISI304
STEEL ELECTRIC GALVANIZED
STEEL SELF COLOR
SGM0018

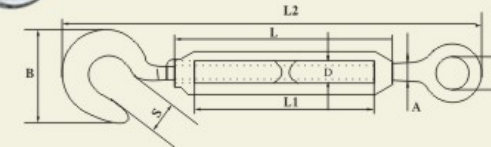

1.HOOK/EYE 2.HOOK/HOOK 3.EYE/EYE

D	L	L1	L2	B	C	S
mm	mm	mm	mm	mm	mm	mm
3/16'(5mm)	70	52	120	13	8	9
1/4'(6mm)	90	78	160	16	10	10
5/16'(8mm)	120	100	200	20	14	11
3/8'(10mm)	150	120	240	28	16	12
1/2'(12mm)	200	168	300	36	18	14
5/8'(16mm)	250	210	390	40	26	16
3/4'(20mm)	300	250	440	50	30	18

TURNBUCKLE EUROPEAN TYPE

STAINLESS STEEL AISI316
STAINLESS STEEL AISI304
STEEL ELECTRIC GALVANIZED
STEEL SELF COLOR
SGM0019



SIZE(D)	L	L1	A	D1
mm	mm	mm	mm	mm
M5	121	70	6	5.2
M6	145	90	7.5	6.2
M8	180	120	10	8.7
M10	225	150	12	9.7
M12	300	200	14	12.6
M16	380	250	16	16

RIGGING SCREW JAW/JAW

STAINLESS STEEL AISI316
STAINLESS STEEL AISI304
SGM0023

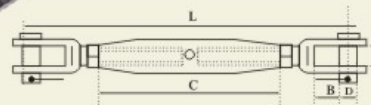

Size	L(Min-Max)	A	B	C	D
mm	mm	mm	mm	mm	mm
M5	130-190mm	7.5	9	80	5
M6	150-220mm	7.5	10	95	5
M8	180-225mm	10	11	105	8
M10	200-300mm	12	13	125	9
M12	270-385mm	14	20	150	12
M14	300-425mm	14	22	165	12
M16	330-480mm	16	26	190	16
M20	360-540mm	20	30	210	20

RIGGING SCREW JAW/SWAGE STUD

STAINLESS STEEL AISI316
STAINLESS STEEL AISI304
SGM0024

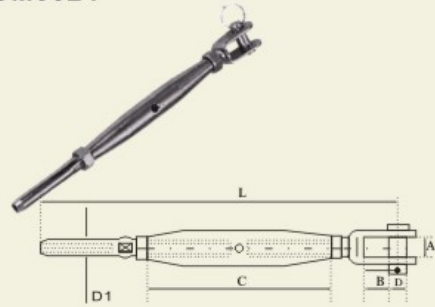

Size	Wire-Φ	L(Min-Max)	A	B	C	D	D1
mm	mm	mm	mm	mm	mm	mm	mm
M5	2.5mm	130-190mm	7.5	10	80	5	5.5
M6	3mm	150-220mm	7.5	10	95	6	6.4
M8	4mm	180-225mm	10	11	105	8	7.5
M10	5mm	200-300mm	12	13	125	9	9
M12	6mm	270-385mm	14	20	150	12	10.7
M14	7mm	300-425mm	14	22	165	12	12.7
M16	8mm	350-475mm	16	26	190	16	16
M20	10mm	390-540mm	20	30	210	20	17.8

TURNBUCKLE WITH TERMINAL/SWIVEL TOGGLE

STAINLESS STEEL AISI 316
STAINLESS STEEL AISI 304
SGM0024-1

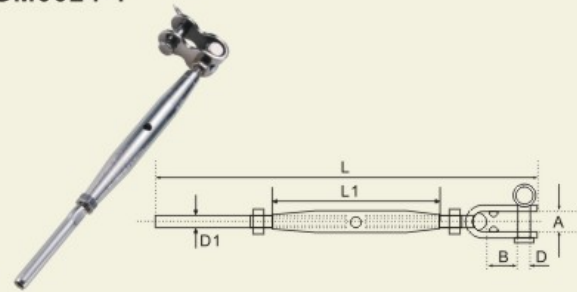

D1	Ø	L1	L	A	D	B
mm	mm	mm	mm	mm	mm	mm
M6	3	95	180	7	6	15
M8	4	105	210	10	8	20
M10	5	125	250	12	9	25
M12	6	150	300	13	12	30
M16	8	190	390	17	16	40
M20	10	210	450	20	19	45

TURNBUCKLE WITH JAW/SWIVEL TOGGLE

STAINLESS STEEL AISI 316
STAINLESS STEEL AISI 304
SGM0024-2

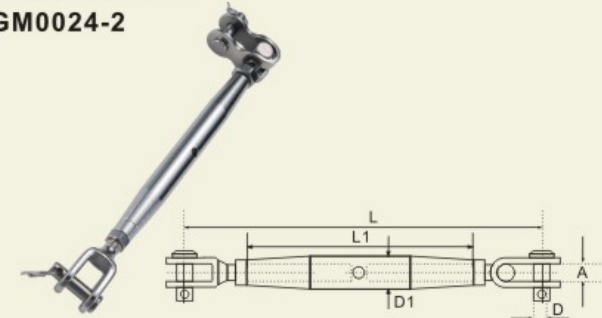

SIZE	D1	D1	L1	A	L	L1
mm	mm	mm	mm	mm	mm	mm
M6	M6	6	95	7	144	90
M8	M8	8	105	10	173	105
M10	M10	9	125	12	207	125
M12	M12	12	150	13	251	150
M16	M16	16	190	17	332	190
M20	M20	19	210	19	375	210

RIGGING SCREW BODY

STAINLESS STEEL AISI316
STAINLESS STEEL AISI304
STEEL ELECTRIC GALVANIZED
STEEL SELF COLOR
SGM0025

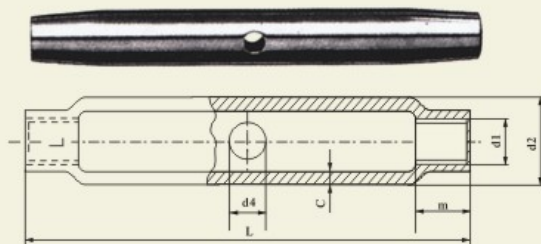

d1	d2	d4	c	L	m
mm	mm	mm	mm	mm	mm
M12	22	10	4.0	125	15
M16	27	10	4.5	170	20
M20	32	12	5.0	210	24
M24	38	12	5.0	255	29
M27	42	14	5.5	255	34
M30	46	16	6.0	255	36
M36	56	16	8.0	295	43
M42	65	20	8.8	330	51
M48	73	20	10.0	355	58
M56	80	25	10.0	355	68
M64	89	25	10.0	425	77
M72	110	30	17.0	425	87
M80	120	30	18.0	440	96

JAW SWAGE TERMINAL

STAINLESS STEEL AISI316
STAINLESS STEEL AISI304
SGM0031

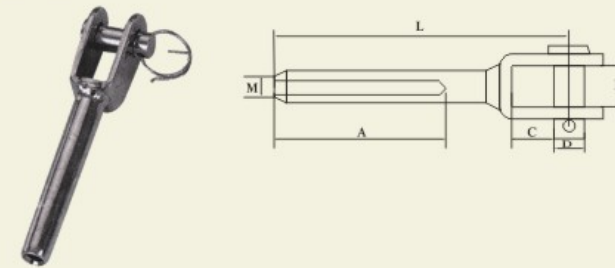

Wire-Φ	L	A	B	C	D
mm	mm	mm	mm	mm	mm
2.5	55	24	7.5	9	5
3	65	32	7.5	10	5
4	77	40	10	11	5
5	88	57	12	13	8
6	106	63	14	20	9
7	116	70	14	22	12
8	145	85	16	26	16
9	150	87	20	30	20
10	150	89	20	30	20

JAW TERMINAL

STAINLESS STEEL AISI316
STAINLESS STEEL AISI304
SGM0032

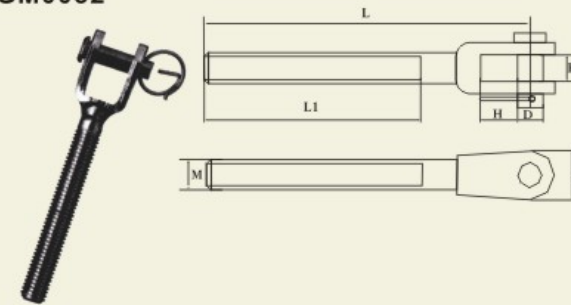

Size	L	L1	H	B	C	D
mm	mm	mm	mm	mm	mm	mm
M5	60.5	41	9	7.5	12	5
M6	72.5	50	10	7.5	14	5
M8	79	55	11	10	17.5	8
M10	96	67	13	12	20	9
M12	118.5	81	20	14	26	12
M14	130	89	22	14	26	12
M16	154	104	26	16	36	16
M20	172	116	30	20	43	20

JAW SWAGE TERMINAL

STAINLESS STEEL AISI316
STAINLESS STEEL AISI304
SGM0033

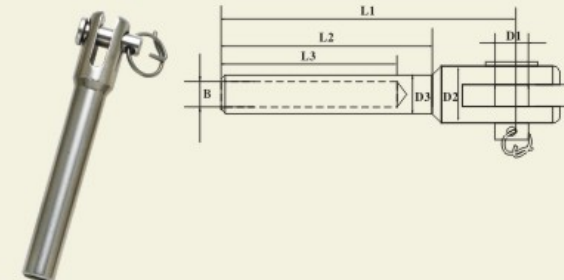

Ø	A	B	D1	D2	D3	L1	L2	L3
mm	mm	mm	mm	mm	mm	mm	mm	mm
3	5.5	3.5	5	11	5.5	41.5	30	25
4	6.5	4.4	5	13	6.35	43.5	31.5	25
5	6.5	5.3	5	13	7.5	51	36	30
6	8.5	6.5	6	16	9.0	67	48.5	40

JAW TERMINAL WITH SCREW

STAINLESS STEEL AISI316
STAINLESS STEEL AISI304
SGM0034

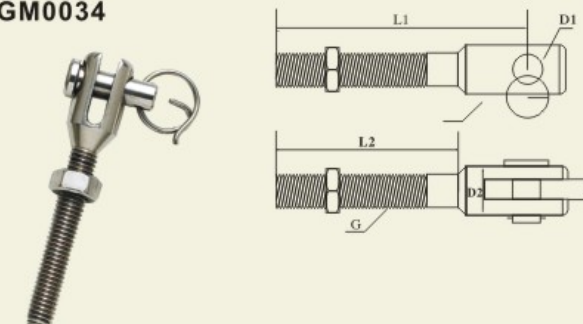

G	A	D1	D2	L1	L2
mm	mm	mm	mm	mm	mm
M5	5.5	5.0	11	42.5	31.0
M6	6.5	5.0	13	48.0	36.0
M8	8.5	8.0	16	60.5	42.0
M10	8.5	9.0	18	71.5	47

EYE SWAGE TERMINAL

STAINLESS STEEL AISI316
STAINLESS STEEL AISI304
SGM0036

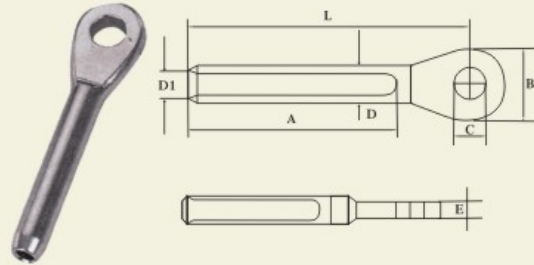

Wire-Φ mm	L mm	A mm	B mm	C mm	D mm	D1 mm	E mm
2.5	44.5	30	13	6.0	5.5	2.8	3
3	57.5	36	13	6.5	6.4	3.5	4
4	65	39	18	8.0	7.5	4.4	5
5	80	50	22	10.0	9	5.3	6
6	94	62	28	12.5	12.7	6.5	8
7	105	68	28	12.7	14	7.5	9
8	124	85	32	14.5	16	8.4	10
10	142	90	36	16.4	17.8	10.5	12

EYE TERMINAL WITH THREAD AND WASHER

STAINLESS STEEL AISI316
STAINLESS STEEL AISI304
SGM0038

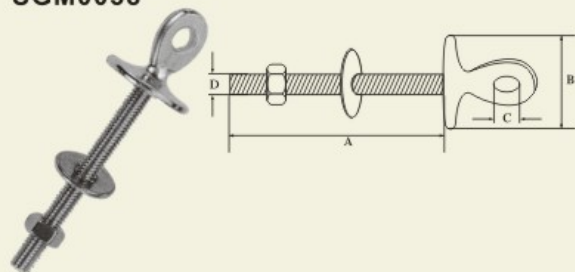

SIZE mm	A mm	B mm	C mm	D mm
M6	45	25	6.5	6
M6	60	25	6.5	6
M8	70	25	8.5	8
M8	80	25	8.5	8

SWAGE STUD

STAINLESS STEEL AISI316
STAINLESS STEEL AISI304
SGM0039

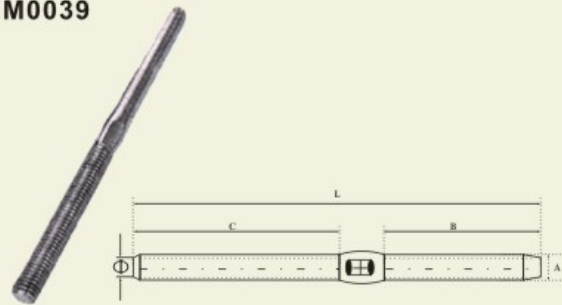

Φ mm	Thread mm	Wire-Φ mm	L mm	A mm	B mm	C mm
2.8	M5	2.5mm	70	5.5	24	38
2.8	M6	2.5mm	72	6.3	24	40
3.5	M6	3mm	80	7.5	32	40
4.4	M6	4mm	95	7.5	40	44
4.4	M8	4mm	102	7.5	40	52
5.3	M8	5mm	120	9.0	57	52
5.3	M10	5mm	130	9.0	57	63
6.5	M10	6mm	136	12.5	63	63
7.5	M12	6mm	142	12.5	63	68
7.5	M12	7mm	148	14.0	70	68
8.4	M14	7mm	160	14.0	70	79
8.4	M14	8mm	165	16.0	76	79
9.5	M16	8mm	175	16.0	76	89
9.5	M16	9mm	190	17.8	89	89
10.5	M20	10mm	230	17.8	89	120

SWAGE DOME HEAD

STAINLESS STEEL AISI316
STAINLESS STEEL AISI304
SGM0040

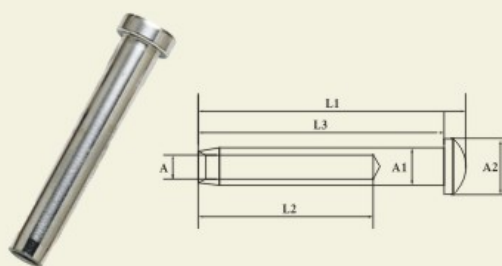

FUNE mm	FUNE POLL mm	L1 mm	L2 mm	L3 mm	A mm	A1 mm	A2 mm	KG/100 mm
3.0	1/8"	35	25	32	3.5	5.5	8	0.5
4.0	5/32"	35	25	32	4.4	6.35	10.0	0.7
5.0	3/16"	47	30	41	5.3	7.5	11.5	1.0
6.0	1/4"	52	40	47	6.5	9.0	14.0	1.9
8.0	5/16"	66	50	60	8.4	12.58	18.0	5.0
10.0	3/8"	77	60	70	10.5	16.0	22.0	9.2

DIN 741 WIRE ROPE CLIPS

STAINLESS STEEL AISI316
STAINLESS STEEL AISI304
STEEL ELECTRIC GALVANIZED
SGM0041

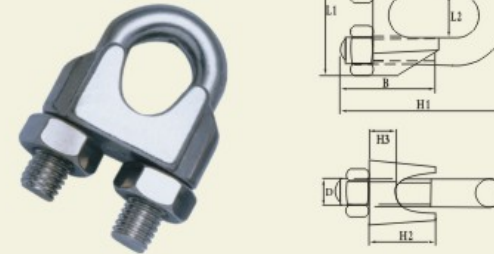

Size mm	D mm	B mm	H1 mm	H2 mm	H3 mm	L1 mm	L2 mm
3mm	M4	12	20	7.5	3.7	17.8	4.8
5mm	M5	13	24	8.2	3.9	22	5.1
6mm	M5	13	28	10.6	5	23.5	7
8mm	M6	20	34	11.7	6	27.4	9.5
10mm	M8	21	42	13	6.3	31.8	10
11mm	M8	24.5	44.5	16	6.5	36.5	12
13mm	M10	30	55	19.5	7.5	42	13
14mm	M10	30	57	23.8	7.7	44	14.5
16mm	M12	33	63.5	26.2	9.5	49.7	17.6
19mm	M12	38	75	31.3	10.8	54.4	22.5
22mm	M12	44	85	34.5	10.8	57.5	22.9
26mm	M14	45	95	35	11	64	27.5

US TYPE WIRE ROPE CLIPS

STAINLESS STEEL AISI316
STAINLESS STEEL AISI304
STEEL ELECTRIC GALVANIZED
SGM0042

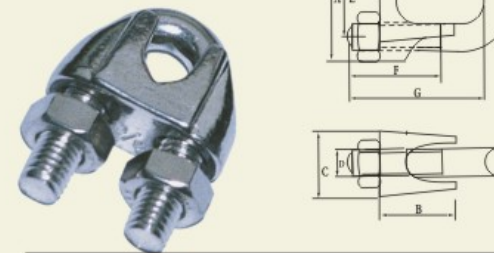

Size(inch) mm	A mm	B mm	C mm	D mm	E mm	F mm	G mm
1/16	13/16	13/12	15/32	3/16	3/8	1/2	23/32
1/8	7/8	7/16	9/16	3/16	7/16	9/16	25/32
3/16	1 1/32	1/2	9/32	1/4	9/16	21/32	15/16
1/4	1 1/4	19/32	23/32	5/16	21/32	25/32	1 1/4
5/16	1 1/4	5/8	25/32	5/16	23/32	7/8	1 11/32
3/8	1 1/2	7/8	7/8	3/8	7/8	1 1/4	1 11/32
7/16	1 3/4	29/32	29/32	3/8	31/32	1 1/4	1 11/32
1/2	1 11/16	29/32	1 1/32	7/16	1 1/16	1 1/2	2 1/4
9/16	2 1/4	1 1/32	1 1/32	1/2	1 1/16	1 1/2	2 1/2
5/8	2 1/2	1 1/32	1 1/4	1/2	1 1/16	1 1/2	2 11/32
3/4	2 3/4	1 1/32	1 1/2	9/16	1 1/4	1 11/16	2 11/16
7/8	2 11/16	1 1/2	1 11/32	5/8	1 1/2	1 11/16	3 1/16
1	3 1/16	1 1/16	1 11/32	5/8	1 1/2	2 1/16	3 1/16

SIMPLEX WIRE ROPE CLIP

STAINLESS STEEL AISI316
STAINLESS STEEL AISI304
STEEL ELECTRIC GALVANIZED
SGM0048

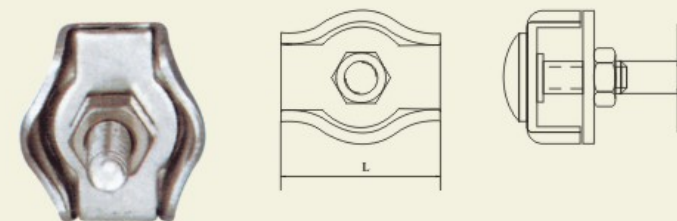

SIZE mm	L mm	D mm
2		M4
3	20	M4
4	21.5	M5
5	26	M6
6	30	M6
8	36	M8
10	42	M10

DUPLEX WIRE ROPE CLIP

STAINLESS STEEL AISI316
STAINLESS STEEL AISI304
STEEL ELECTRIC GALVANIZED
SGM0049



SIZE mm	L mm	D mm
2	37	M4
3	40	M4
4	43	M5
5	52	M6
6	60	M6
8	72	M8
10	84	M10

THIMBLE DIN 6899A

STAINLESS STEEL AISI316
STAINLESS STEEL AISI304
STEEL ELECTRIC GALVANIZED
SGM0050

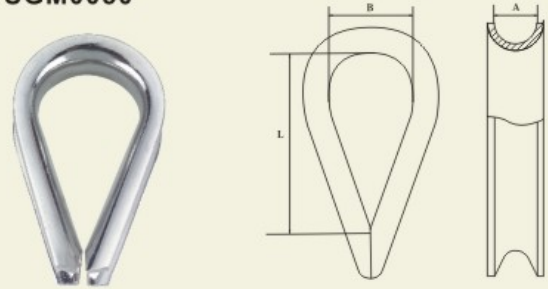

Seil- \varnothing mm	A mm	B mm	L mm
2.5	3.0	10	21.5
3.0	3.5	11	23.5
3.5	4.0	12	26.5
4.0	5.0	13	28.5
5.0	6.0	14	30.0
6.0	7.0	15	33.0
7.0	8.0	16	35.0
8.0	9.0	18	39.0
9.0	10.0	20	43.0

Seil- \varnothing mm	A mm	B mm	L mm
10.0	11.0	22	47.5
11.0	12.0	24	51.5
12.0	13.0	26	56.5
13.0	14.0	28	61.0
15.0	16.0	32	69.5
16.0	18.0	35	78.0
18.0	20.0	40	86.5
20.0	22.0	44	95.0
24/26	26.0	48	105.0

U.S THIMBLE G-411

STAINLESS STEEL AISI316
STAINLESS STEEL AISI304
STEEL ELECTRIC GALVANIZED
SGM0052

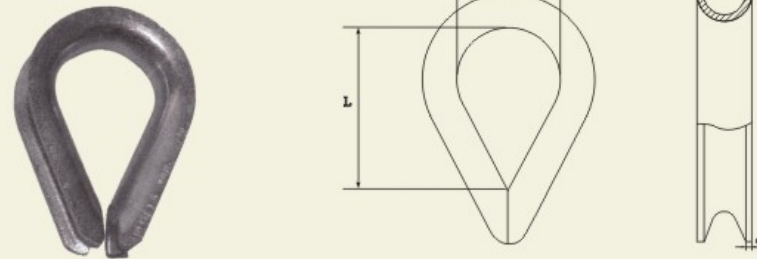

Seil- \varnothing mm	A mm	B mm	C mm	L mm
1/8"	4	17	1.2	33
3/16"	5	17.5	1.2	33
1/4"	7	18	1.2	33
5/16"	8.6	20.5	1.2	38
3/8"	10.4	24	1.5	42
1/2"	13.5	29	2	48
5/8"	16.8	35	3	57
3/4"	19.8	41	3.5	64
7/8"	23.8	48	4	89
1"	27	64	4	108
1 1/8-1 1/4"	33	70	5.5	115

U.S THIMBLES G-414

STAINLESS STEEL AISI316
STAINLESS STEEL AISI304
STEEL ELECTRIC GALVANIZED
SGM0053

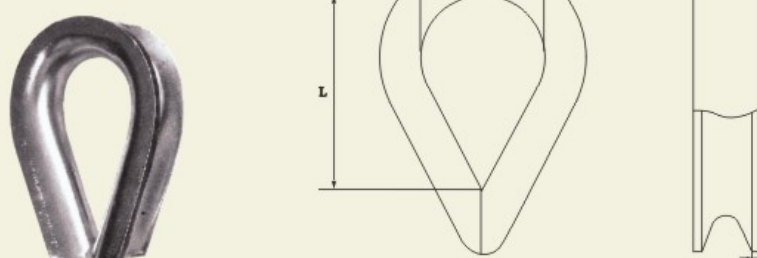

Seil- \varnothing mm	A mm	B mm	C mm	L mm
1/4"	7	22	1.5	41
5/16"	8.6	27	2	48
3/8"	10.4	29	3	54
7/16"	12	32	3	61
1/2"	13.5	38	3.5	70
9/16"	15	38	3.5	72
5/8"	16.8	44	4	82
3/4"	19.8	51	5.5	95
7/8"	24	57	5.5	108
1"	27	64	6	114
1 1/8-1 1/4"	33	73	6	130

THIMBLES EUROPEAN COMMERCIAL

STAINLESS STEEL AISI316
STAINLESS STEEL AISI304
STEEL ELECTRIC GALVANIZED
SGM0055

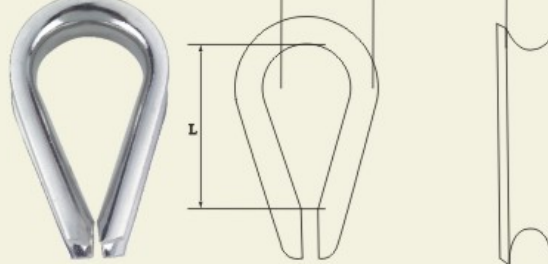

SIZE mm	A mm	B mm	L mm
4	4	11	16
5	5	16	22
6	6	19	26
7	7	22	32
8	8	24	34
9	9	29	38
10	10	32	42
11	11	35	48

SIZE	A	B	L
12	12	38	51
14	14	40	57
16	16	42	60
18	18	45	67
20	20	51	76
22	22	54	83
24	24	64	88
26	26	68	102
28	28	73	110

TUBE THIMBLES

STAINLESS STEEL AISI316
STAINLESS STEEL AISI304
SGM0056



For rope dia mm	A mm	B mm	C mm	D mm
10	12	90	23	4
12	15	105	27	5
14	17	115	27	4
16	19	120	32	5
18	22	140	35	5
22	25	180	45	6
25	30	195	47	7
32	35	215	60	7
38	45	260	70	7

EUROPEAN SWIVEL EYE AND EYE

STAINLESS STEEL AISI316
STAINLESS STEEL AISI304
SGM0057

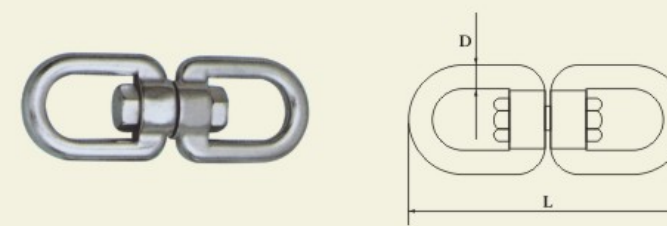

SIZE mm	D mm	L mm
5	5	59
6	6	65
8	8	90
10	10	115
13	13	152
16	16	188
19	19	229

EUROPEAN SWIVEL EYE AND JAW

STAINLESS STEEL AISI316
STAINLESS STEEL AISI304
SGM0058

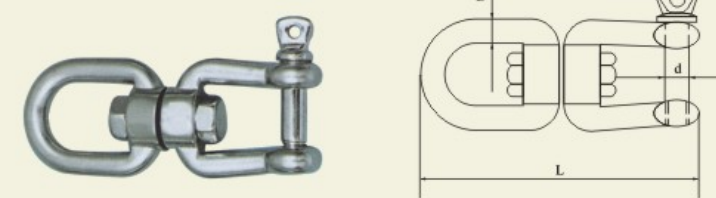

SIZE mm	D mm	d mm	L mm
5	5	5	59
6	6	6	66
8	8	8	94
10	10	10	118
13	13	13	152
16	16	16	188
19	19	19	229

EUROPEAN SWIVEL JAW AND JAW

STAINLESS STEEL AISI316
STAINLESS STEEL AISI304
SGM0059

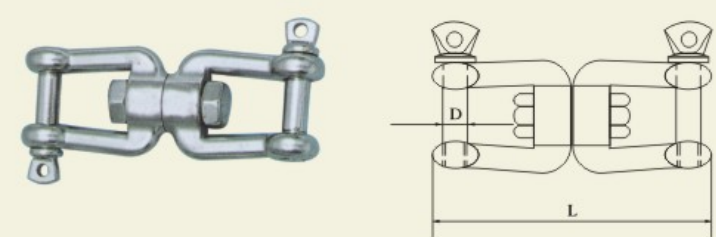

SIZE mm	D mm	L mm
5	5	59
6	6	66
8	8	94
10	10	118
13	13	152
16	16	188
19	19	229

SNAP HOOK WITH EYELET DIN5299 FORM A

STAINLESS STEEL AISI316
STAINLESS STEEL AISI304
STEEL ELECTRIC GALVANIZED

SGM0063

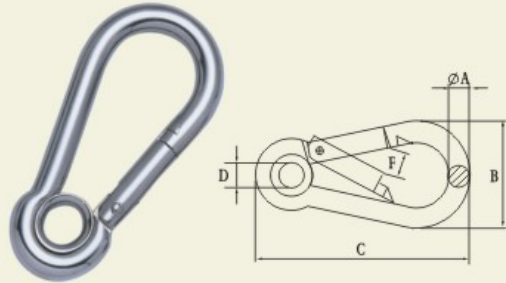

SIZE	∅ A	B	C	D	F	W.L.L.
mm	mm	mm	mm	mm	mm	LBS
4X40	4	20	40	5	7	80
5X50	5	25	50	5	7	100
6X60	6	30	60	5	8	140
7X70	7	35	70	7	8	200
8X80	8	40	80	10	9	250
9X90	9	45	90	10	10	280
10X100	10	50	100	13	11	400
11X120	11	57	120	13	16	500
12X140	12	67	140	15	19	600
13X160	13	74	160	17	25	700
14X180	14	86	180	17	35	900

EGG TYPE SNAP HOOK DIN5299 FORM B

STAINLESS STEEL AISI316
STAINLESS STEEL AISI304
STEEL ELECTRIC GALVANIZED

SGM0064

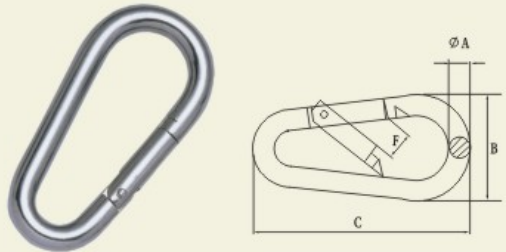

SIZE	∅ A	B	C	F	W.L.L.
mm	mm	mm	mm	mm	LBS
5X50	5	25	50	7	100
6X60	6	30	60	8	140
7X70	7	35	70	8	200
8X80	8	40	80	9	250
9X90	9	45	90	10	280
10X100	10	50	100	11	400
11X120	11	57	120	16	500
12X140	12	67	140	19	600

SNAP HOOK DIN5299 FORM C

STAINLESS STEEL AISI316
STAINLESS STEEL AISI304
STEEL ELECTRIC GALVANIZED

SGM0065

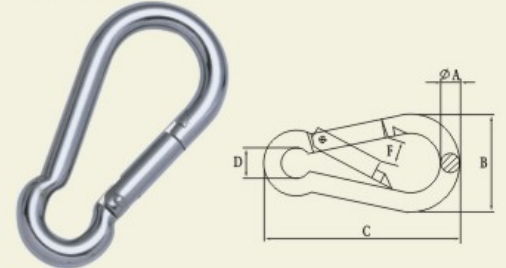

SIZE	∅ A	B	C	D	F	W.L.L.
mm	mm	mm	mm	mm	mm	LBS
4X40	4	20	40	7	7	80
5X50	5	25	50	8	7	100
6X60	6	30	60	9	8	140
7X70	7	35	70	10	8	200
8X80	8	40	80	12	9	250
9X90	9	45	90	12	10	280
10X100	10	50	100	15	11	400
11X120	11	57	120	18	16	500
12X140	12	67	140	20	19	600
13X160	13	74	160	22	25	700
14X180	14	86	180	22	35	900

SNAP HOOK WITH SCREW DIN5299 FORM D

STAINLESS STEEL AISI316
STAINLESS STEEL AISI304
STEEL ELECTRIC GALVANIZED

SGM0066

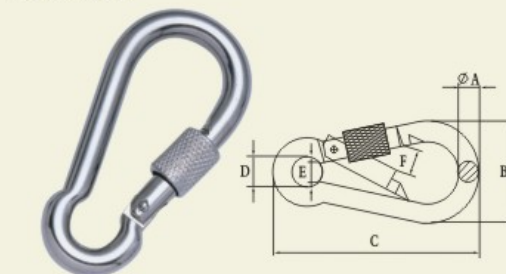

SIZE	∅ A	B	C	D	F	W.L.L.
mm	mm	mm	mm	mm	mm	LBS
4X40	4	20	40	7	7	80
5X50	5	25	50	8	7	100
6X60	6	30	60	9	8	140
7X70	7	35	70	10	8	200
8X80	8	40	80	12	9	250
9X90	9	45	90	12	10	280
10X100	10	50	100	15	11	400
11X120	11	57	120	18	16	500
12X140	12	67	140	20	19	600
13X160	13	74	160	22	25	700
14X180	14	86	180	22	35	900

STRAIGHT SNAP HOOK

STAINLESS STEEL AISI316
STAINLESS STEEL AISI304
STEEL ELECTRIC GALVANIZED

SGM0068

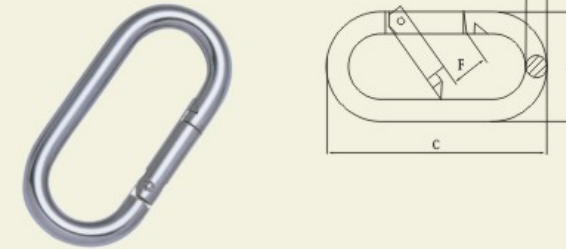

SIZE	∅ A	B	C	F	W.L.L.
mm	mm	mm	mm	mm	LBS
5X50	5	25	50	9	100
6X60	6	30	60	11	140
8X80	8	40	80	13	250
10X100	10	50	100	16	400
11X120	11	58	120	21	500

STRAIGHT SNAP HOOK WITH SCREW

STAINLESS STEEL AISI316
STAINLESS STEEL AISI304
STEEL ELECTRIC GALVANIZED

SGM0069

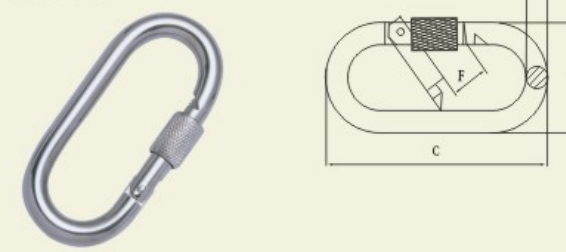

SIZE	∅ A	B	C	F	W.L.L.
mm	mm	mm	mm	mm	LBS
5X50	5	25	50	9	100
6X60	6	30	60	11	140
8X80	8	40	80	13	250
10X100	10	50	100	16	400
11X120	11	58	120	21	500

LONG STRAIGHT SNAP HOOK

STAINLESS STEEL AISI316
STAINLESS STEEL AISI304
STEEL ELECTRIC GALVANIZED

SGM0070

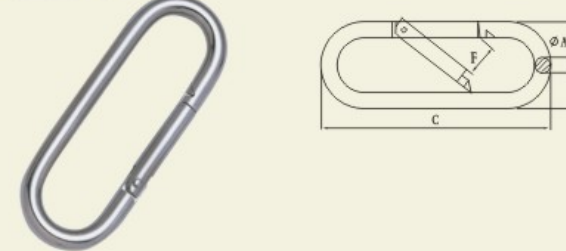

SIZE	∅ A	B	C	F	W.L.L.
mm	mm	mm	mm	mm	LBS
5X67	5	25	67	9	100
6X80	6	30	80	10	140
8X95	8	40	95	12	250

SNAP HOOK WITH EYELET AND SCREW

STAINLESS STEEL AISI316
STAINLESS STEEL AISI304
STEEL ELECTRIC GALVANIZED

SGM0071

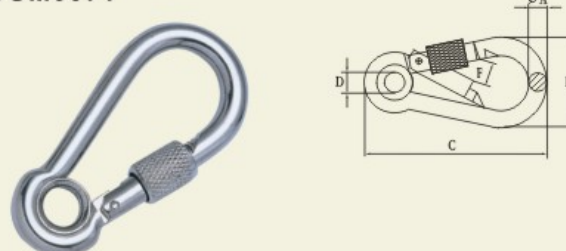

SIZE	∅ A	B	C	D	F	W.L.L.
mm	mm	mm	mm	mm	mm	LBS
5X50	5	25	50	5	7	100
6X60	6	30	60	5	8	140
7X70	7	35	70	7	8	200
8X80	8	40	80	10	9	250
9X90	9	45	90	10	10	280
10X100	10	50	100	13	11	400
11X120	11	57	120	13	16	500
12X140	12	67	140	15	19	600
13X160	13	74	160	17	25	700
14X180	14	86	180	17	35	900

OBLIQUE ANGLE SNAP HOOK

STAINLESS STEEL AISI316
STAINLESS STEEL AISI304
STEEL ELECTRIC GALVANIZED
SGM0072

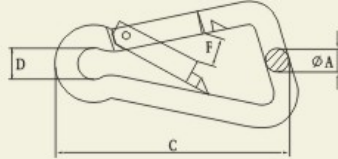

SIZE	Ø A	C	D	F	W.L.L.
mm	mm	mm	mm	mm	LBS
5X50	5	50	8	9	100
6X60	6	60	9	10	140
8X80	8	80	12	13	250
10X100	10	100	15	18	400
11X120	11	120	15	24	500

OBLIQUE ANGLE SNAP HOOK WITH EYELET

STAINLESS STEEL AISI316
STAINLESS STEEL AISI304
STEEL ELECTRIC GALVANIZED
SGM0073

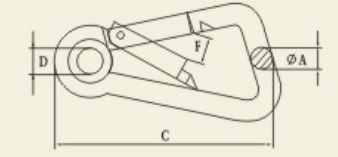

SIZE	Ø A	C	D	F	W.L.L.
mm	mm	mm	mm	mm	LBS
5X50	5	50	5	9	100
6X60	6	60	5	10	140
8X80	8	80	10	13	250
10X100	10	100	13	18	400
11X120	11	120	13	24	500

OBLIQUE ANGLE SNAP HOOK WITH EYELET AND SPRING PIN

STAINLESS STEEL AISI316
STAINLESS STEEL AISI304
STEEL ELECTRIC GALVANIZED
SGM0074

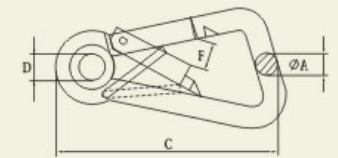

SIZE	Ø A	C	D	F	W.L.L.
mm	mm	mm	mm	mm	LBS
5X50	5	50	5	9	100
6X60	6	60	5	10	140
8X80	8	80	10	13	250
10X100	10	100	13	18	400
11X120	11	120	13	24	500

OBLIQUE ANGLE SNAP HOOK WITH EYELET AND RIVETS AT BOTH END

STAINLESS STEEL AISI316
STAINLESS STEEL AISI304
STEEL ELECTRIC GALVANIZED
SGM0075

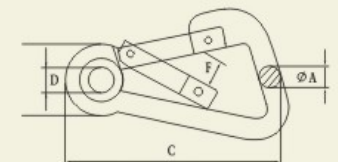

SIZE	Ø A	C	D	F	W.L.L.
mm	mm	mm	mm	mm	LBS
10x90	10	90	13	13	400

SIMPLE SNAP HOOK

STAINLESS STEEL AISI316
STAINLESS STEEL AISI304
STEEL ELECTRIC GALVANIZED
SGM0076

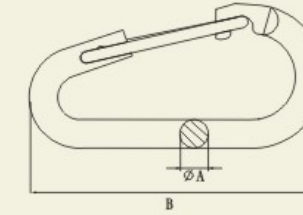

SIZE	Ø A	B
mm	mm	mm
6X60	6	60
8X80	8	80

SPRING HOOK

STAINLESS STEEL AISI316
STAINLESS STEEL AISI304
STEEL ELECTRIC GALVANIZED
SGM0077

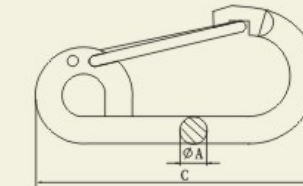

SIZE	Ø A	C
mm	mm	mm
6X60	6	60
8X80	8	80

DELTA SIMPLE SNAP HOOK

STAINLESS STEEL AISI316
STAINLESS STEEL AISI304
STEEL ELECTRIC GALVANIZED
SGM0078

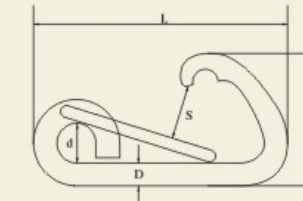

D	L	W	S	d
mm	mm	mm	mm	mm
6	61	35	11	9
8	81	46	18	11
10	102	58	22	15
12	120	70	26	18

SNAP HOOK WITH BAR

STAINLESS STEEL AISI316
STAINLESS STEEL AISI304
SGM0078-5

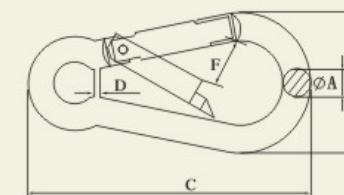

SIZE	Ø A	B	C	D	F
mm	mm	mm	mm	mm	mm
13X160	13	80	160	3	33

422. SNAP HOOK

STAINLESS STEEL AISI316
STAINLESS STEEL AISI304
SGM0078-7

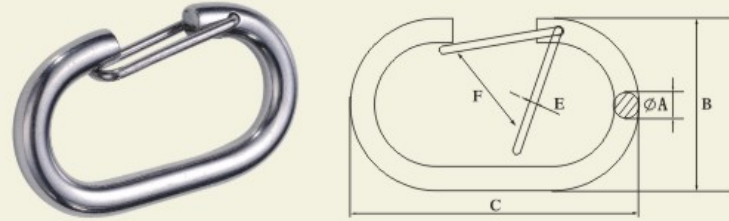

SIZE	∅ A	B	C	E	F
mm	mm	mm	mm	mm	mm
422-4	4	17	40	1.6	6
422-5	5	15	50	2.0	8
422-6	6	35	60	2.5	12
422-8	8	40	70	2.5	14
422-10	10	45	80	3.2	15

SNAP HOOK WITH TWO RIVETS

STAINLESS STEEL AISI316
STAINLESS STEEL AISI304
STEEL ELECTRIC GALVANIZED
SGM0079

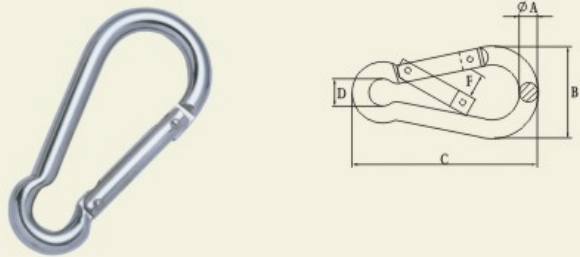

SIZE	∅ A	B	C	D	F	W.L.L
mm	mm	mm	mm	mm	mm	LBS
5X50	5	25	50	8	7	100
6X60	6	30	60	9	8	140
7X70	7	35	70	10	8	200
8X80	8	40	80	12	9	250
9X90	9	45	90	12	10	280
10X100	10	50	100	15	11	400
11X120	11	57	120	18	16	500
12x140	12	67	140	20	19	600

SNAP HOOK

STAINLESS STEEL AISI316
STAINLESS STEEL AISI304
STEEL ELECTRIC GALVANIZED
SGM0081

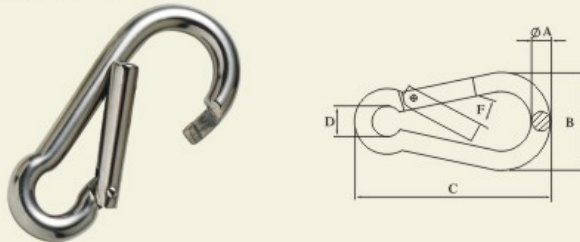

SIZE	∅ A	B	C	D	F
mm	mm	mm	mm	mm	mm
5X50	5	25	50	8	7
6X60	6	30	60	9	8
7X70	7	35	70	10	8
8X80	8	40	80	12	9
9X90	9	45	90	12	10
10X100	10	50	100	15	11
11X120	11	57	120	18	16
12x140	12	67	140	20	19

QUICK LINK

STAINLESS STEEL AISI316
STAINLESS STEEL AISI304
STEEL ELECTRIC GALVANIZED
SGM0082

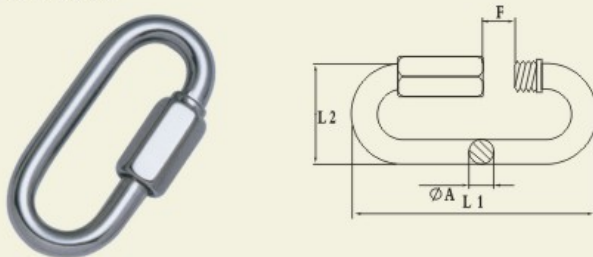

SIZE	∅ A	L1	L2	F	W.L.L
mm	mm	mm	mm	mm	LBS
3.5	3.5	36.5	17	5	175
4	4	40	19.5	5.5	500
5	5	49	23	6.5	650
6	6	58	26.5	7.5	875
7	7	65	30.5	8.5	1200
8	8	75	33.5	10.5	1525
9	9	82	35	11.5	1975
10	10	90	40.5	12.5	2300
12	12	107	47.5	14.5	2500
14	14	125	54.5	17	2800

WIDE JAW QUICK LINK

STAINLESS STEEL AISI316
STAINLESS STEEL AISI304
STEEL ELECTRIC GALVANIZED
SGM0083

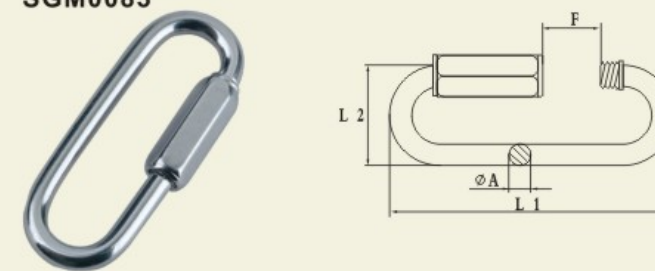

SIZE	∅ A	L1	L2	F	W.L.L
mm	mm	mm	mm	mm	LBS
3.5	3.5	47	17	10	175
5	5	62	23	14	650
6	6	72	26.5	16	875
8	8	90	33.5	18	1525
10	10	105	40.5	20	2300
12	12	122	47.5	23	2500

DELTA SHAPED QUICK LINK

STAINLESS STEEL AISI316
STAINLESS STEEL AISI304
STEEL ELECTRIC GALVANIZED
SGM0084

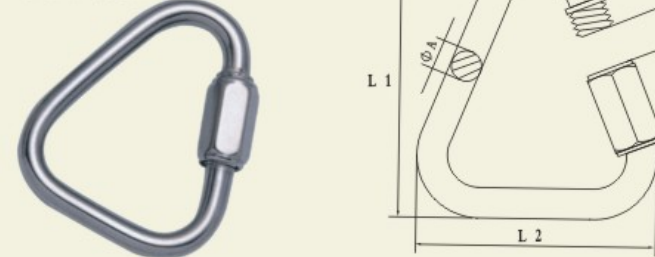

SIZE	∅ A	L1	L2	F	W.L.L
mm	mm	mm	mm	mm	LBS
3.5	3.5	37	31	5	120
5	5	47	40	6	450
6	6	56	47	7.5	600
8	8	73	56	10	1100
10	10	87	66	12	1500
12	12	104	75	15	1650
14	14	122	86	19	1900

PEAR SHAPED QUICK LINK

STAINLESS STEEL AISI316
STAINLESS STEEL AISI304
STEEL ELECTRIC GALVANIZED
SGM0085

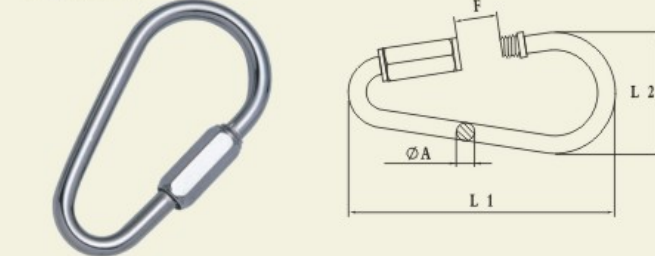

∅ A	L1	L2	F	W.L.L
mm	mm	mm	mm	LBS
3.5	52	27	9.5	120
4	60	32	11	350
5	70	37	12	450
6	81	42.8	14	600
8	100	50.8	17	1100
9	108	57	19	1300
10	117.5	63.5	20.5	1500
12	141	76	23	1650

CARABINE TYPE QUICK LINK

STAINLESS STEEL AISI316
STAINLESS STEEL AISI304
STEEL ELECTRIC GALVANIZED
SGM0086



SIZE	∅ A	L1	L2
mm	mm	mm	mm
6	6	80	32
8	8	100	46

CARABINE TYPE QUICK LINK WITH THIMBLE

STAINLESS STEEL AISI316
STAINLESS STEEL AISI304
STEEL ELECTRIC GALVANIZED
SGM0087

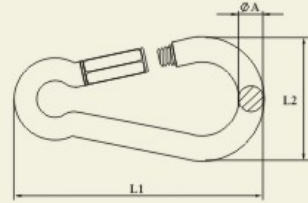

SIZE	∅A	L1	L2
mm	mm	mm	mm
6	6	80	32
8	8	100	46

DIN 582 EYE NUT

STAINLESS STEEL AISI316
STAINLESS STEEL AISI304
STEEL ELECTRIC GALVANIZED
SGM0089

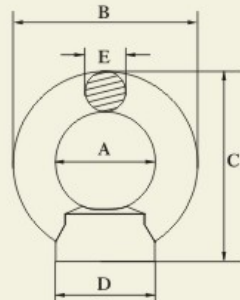

D	A	B	C	E
mm	mm	mm	mm	mm
6	20	36	36	8
8	20	36	36	8
10	25	45	45	10
12	30	54	53	12
14	30	54	53	12
16	35	63	62	14
18	35	63	62	14
20	40	72	71	16
24	50	90	90	20
30	60	108	109	24
36	70	126	128	18

DIN 580 EYE BOLT

STAINLESS STEEL AISI316
STAINLESS STEEL AISI304
STEEL ELECTRIC GALVANIZED
SGM0090

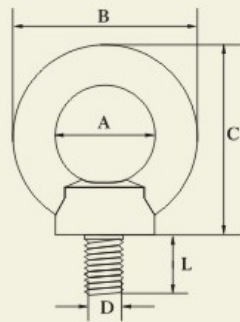

D	A	B	C	L
mm	mm	mm	mm	mm
6	20	36	36	13
8	20	36	36	13
10	25	45	45	17
12	30	54	53	20
14	30	54	53	20
16	35	63	62	27
18	35	63	62	27
20	40	72	71	30
24	50	90	90	36
30	60	108	109	45
36	70	126	128	54

EYE BOLT WITH NUT

STAINLESS STEEL AISI316
STAINLESS STEEL AISI304
STEEL ELECTRIC GALVANIZED
SGM0091

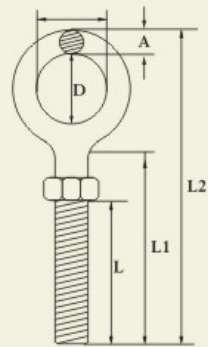

A	D	L	L1	L2
mm	mm	mm	mm	mm
6	13	35	40	64
6	13	55	60	104
6	13	75	80	104
6	13	95	100	124
8	17	55	60	92
8	17	75	80	112
8	17	95	100	132
8	17	125	130	162
10	21	75	80	119
10	21	95	100	139
10	21	115	120	159
10	21	145	150	189
12	25	95	100	146
12	25	145	150	196

LAG SCREW EYE

STAINLESS STEEL AISI316
STAINLESS STEEL AISI304
SGM0091-1

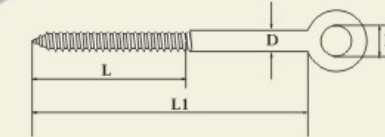
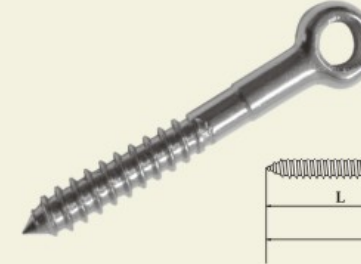

D	D2	L	L1
mm	mm	mm	mm
4	4.2	30	45
6	6.3	32	55
8	8.4	40	60
10	10.5	55	80
12	12.5	65	105

ROUND RING W/SCREW

STAINLESS STEEL AISI316
STAINLESS STEEL AISI304
SGM0092



D	L	H	d	A	B
mm	mm	mm	mm	mm	mm
3	25	45	4	9	4
5	30	55	6	12	6
7	50	56	8	17	9

WIRE EYE STRAP

STAINLESS STEEL AISI316
STAINLESS STEEL AISI304
SGM0094

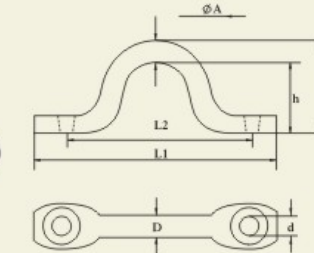

D	L1	L2	H	h	d
mm	mm	mm	mm	mm	mm
4	40	32	16	11	3.2
5	50	40	16	13	4.2
6	57	44	22	16	5.2
8	63	47	25	17	5.2

ROPE SHORTENING WITHOUT TONGUE ZIND PLATED

STAINLESS STEEL AISI316
STAINLESS STEEL AISI304
STEEL ELECTRIC GALVANIZED
SGM0122

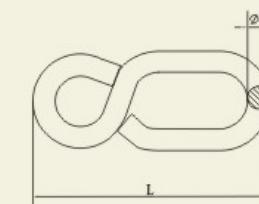

SIZE	∅A	L
mm	mm	mm
5X60	5	60
6X60	6	60
6X70	6	70
7X75	7	75
8X70	8	70
8X80	8	80
9X90	9	90
10X100	10	100

STAMPED EYE STRAP

STAINLESS STEEL AISI316
STAINLESS STEEL AISI304
SGM0095

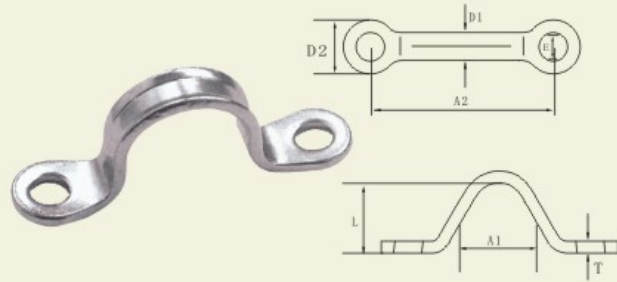

T	E	D2	A2	A1	L	D1
mm	mm	mm	mm	mm	mm	mm
1.5	4.2	9	28	11	12	5
2	5.0	11	34	15	14	6
2	5.3	12	44	20	19	7
2	5.3	12	63	28	28	7
3	6.4	14	67	32	33	8

SQUARE EYE PLATE

STAINLESS STEEL AISI316
STAINLESS STEEL AISI304
SGM0096

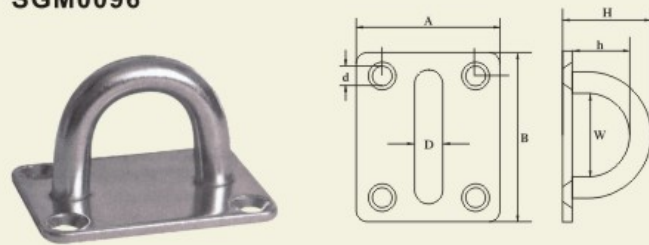

D	A	B	H	h	w	d
mm	mm	mm	mm	mm	mm	mm
5	30	35	19	12	14	4.2
6	35	40	26	17	18	5.2
8	40	50	33	22	20	5.2

SQUARE EYE PLATE WITH RING

STAINLESS STEEL AISI316
STAINLESS STEEL AISI304
SGM0097

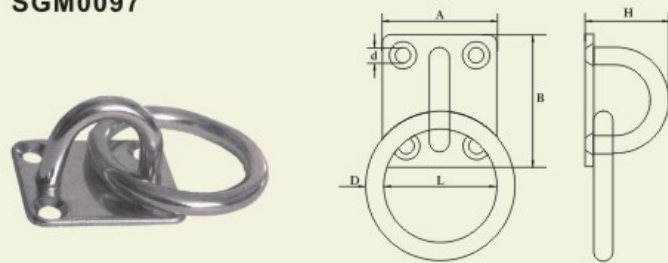

D	A	B	H	d	L
mm	mm	mm	mm	mm	mm
5	30	35	19	4.2	30
6	35	40	26	5.2	40
8	40	50	33	5.2	50

OVAL EYE PLATE WITH RING

STAINLESS STEEL AISI316
STAINLESS STEEL AISI304
SGM0098

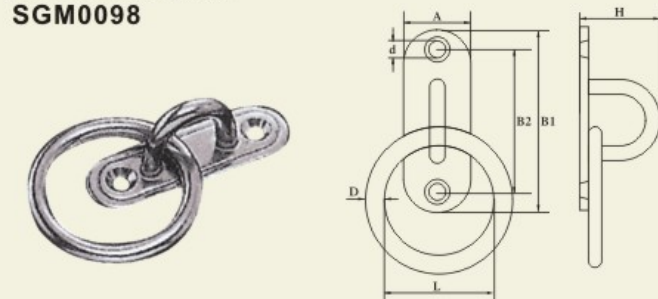

D	A	B1	B2	H	d	L
mm	mm	mm	mm	mm	mm	mm
5	15	45	35.5	20	12	30
6	20	60	46	25	17	40
8	26	80	60	32	21	50
9	32	100	73	38	26	60

OVAL EYE PLATE

STAINLESS STEEL AISI316
STAINLESS STEEL AISI304
SGM0099

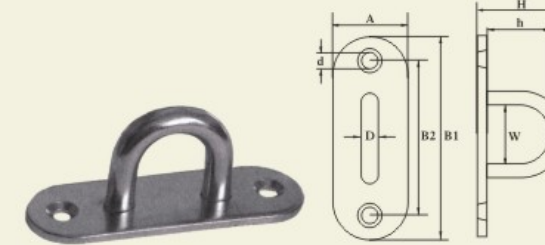

D	A	B1	B2	H	h	W	d
mm	mm	mm	mm	mm	mm	mm	mm
5	15	45	35.5	20	12	14	4.2
6	20	60	46	25	17	18	5.2
8	26	80	60	32	21	20	5.2
9	32	100	73	38	26	22	6.5

ROUND EYE PLATE

STAINLESS STEEL AISI316
STAINLESS STEEL AISI304
SGM0100

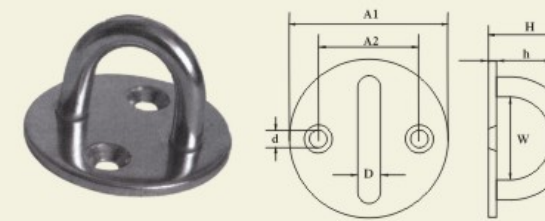

D	A1	A2	H	H1	W	D1
mm	mm	mm	mm	mm	mm	mm
5	33	20	20	12	12	4.2
6	40	23	26	17	17	4.2
8	50	30	32	21	20	5.2

ROUND EYE PLATE WITH RING

STAINLESS STEEL AISI316
STAINLESS STEEL AISI304
SGM0101

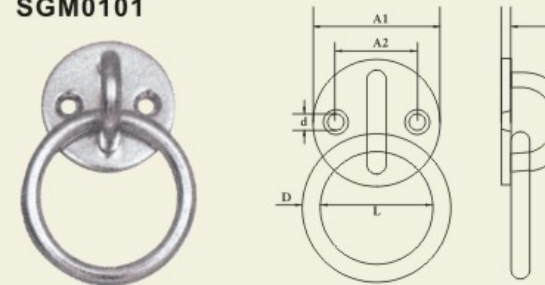

D	A1	A2	H	d	L
mm	mm	mm	mm	mm	mm
5	33	20	20	4.2	30
6	40	23	26	4.2	40
8	50	30	32	5.2	50

DIAMOND EYE PLATE

STAINLESS STEEL AISI316
STAINLESS STEEL AISI304
SGM0102

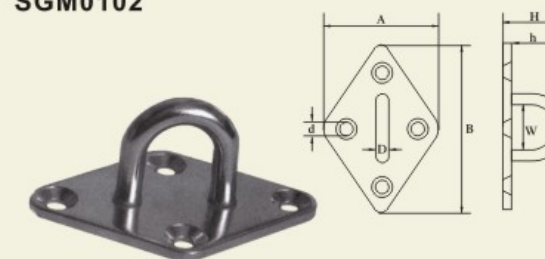

D	A	B	H	h	w	d
mm	mm	mm	mm	mm	mm	mm
5	37	59	22	12	11	4.2
6	50	64	26	15	15	4.2
8	60	80	33	20	18	5.2

DIAMOND EYE PLATE WITH RING

STAINLESS STEEL AISI316
STAINLESS STEEL AISI304
SGM0103

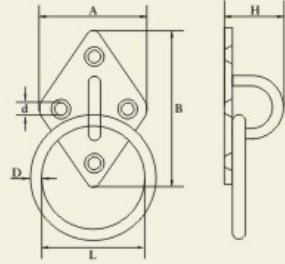

D	A	B	H	d	L
mm	mm	mm	mm	mm	mm
5	37	59	22	4.2	30
6	40	64	26	5.2	35
8	50	80	23	5.2	45

HOOK PLATE

STAINLESS STEEL AISI316
STAINLESS STEEL AISI304
SGM0104

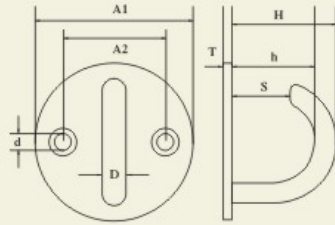

D	A1	A2	H	h	S	d	T
mm	mm	mm	mm	mm	mm	mm	mm
5	33	19	20	12.5	10	4.2	2.5
6	40	23	26	17.5	13	5.2	2.5
8	50	29	33	22	16	5.2	3

ROUND EYE PLATE

STAINLESS STEEL AISI316
STAINLESS STEEL AISI304
SGM0105

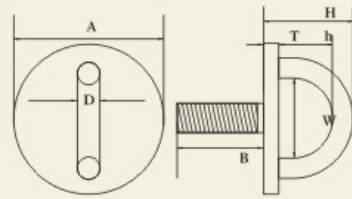

D	A1	H	h	W	B	T
mm	mm	mm	mm	mm	mm	mm
5	33	19	11.5	15	21	2.5
6	40	25.5	17	18	25	2.5
8	50	32	20	22	27	3

ROUND EYE PLATE WITH RING

STAINLESS STEEL AISI316
STAINLESS STEEL AISI304
SGM0106

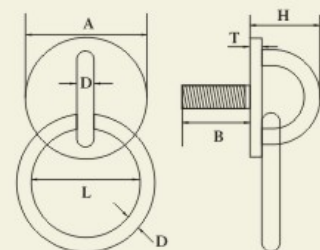

D	L	A	H	B	T
mm	mm	mm	mm	mm	mm
5	30	33	19	21	2.5
6	40	40	25.5	25	2.5
8	50	50	32	27	3

PAD EYE SWIVEL

STAINLESS STEEL AISI 316
STAINLESS STEEL AISI 304
SGM0106-1

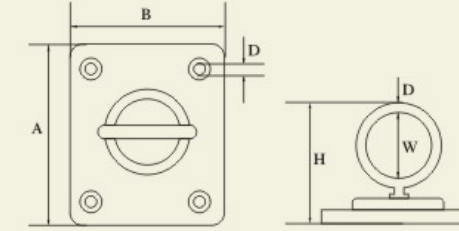

D	A	B	H	W	D
mm	mm	mm	mm	mm	mm
5	35	30	32	15	4.2
6	40	35	40	18	4.2
8	50	40	45	19	5.7

PAD EYE SWIVEL WITH RING

STAINLESS STEEL AISI 316
STAINLESS STEEL AISI 304
SGM0106-2

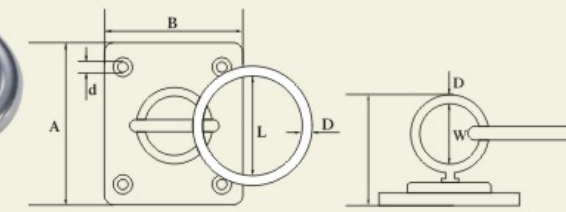

D	A	B	H	W	D
mm	mm	mm	mm	mm	mm
5	35	30	32	15	4.2
6	40	35	40	18	4.2
8	50	40	45	19	5.7

CHAIN HOOK

STAINLESS STEEL AISI 304
SGM0106-5

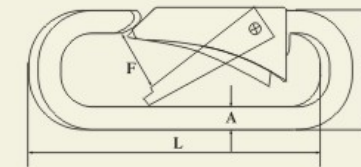

A	B	F	L
mm	mm	mm	mm
6	25.5	11	80

OPEN HOOK

STAINLESS STEEL AISI 304
SGM0106-6

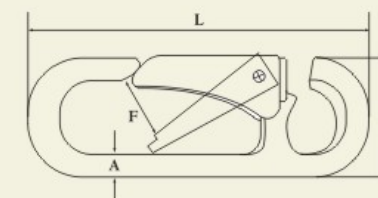

A	B	F	L
mm	mm	mm	mm
6	25.5	11	80

TOGGLE

SSTAINLESS STEEL AISI 316
SSTAINLESS STEEL AISI 304
SGM0106-7

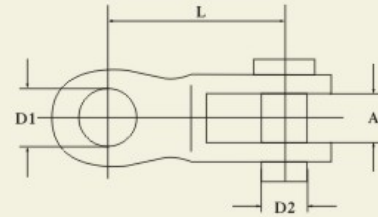

SIZE	D1	D2	A	L
mm	mm	mm	mm	mm
5	5.5	5.2	7.0	22
6	6.6	6.3	7.0	27
8	8.5	8.3	10.0	31
10	10.0	9.3	12.0	36
12	13.0	12.4	13.0	50
14	15.0	14.0	13.0	60
16	16.5	15.5	17.0	80

DOOR HINGE

SSTAINLESS STEEL AISI 316
SSTAINLESS STEEL AISI 304
SGM0106-8

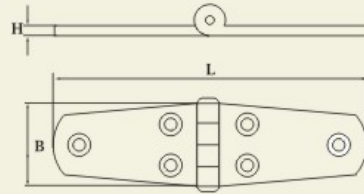

L	B	H
mm	mm	mm
74	38	4.5

STAINLESS STEEL CLEAT

SSTAINLESS STEEL AISI 316
SSTAINLESS STEEL AISI 304
SGM0106-9

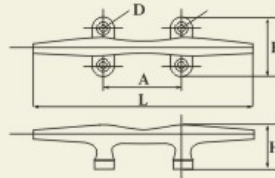

SIZE	L	B	H	D	A
mm	mm	mm	mm	mm	mm
5"	125	40	23	5	56
6"	150	45	32	7	63
8"	200	53	39	6.5	70
10"	250	66	43	7	95
12"	300	70	55	7	102

SPRING SNAP

SSTAINLESS STEEL AISI 316
SSTAINLESS STEEL AISI 304
SGM0106-10

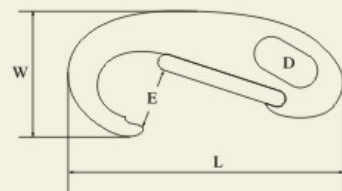

L	W	E	D
mm	mm	mm	mm
50	24	10	6.5
70	31	13	10.0
100	46	23	13.0

PELICAN HOOK

SSTAINLESS STEEL AISI 316
SSTAINLESS STEEL AISI 304
SGM0106-11

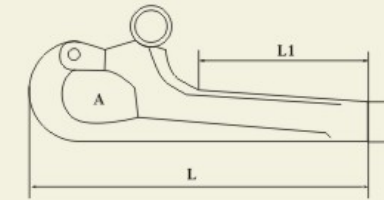

L	L1	A	B
mm	mm	mm	mm
76	39	13	M6X9
100	48	16	M8X12

FIXED SNAP SHACKLE

SSTAINLESS STEEL AISI 316
SSTAINLESS STEEL AISI 304
SGM0106-12

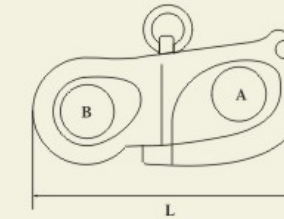

L	A	B
mm	mm	mm
52	12	9
66	16	12
96	22	16

SWIVEL SNAP SHACKLE ROUND HEAD

SSTAINLESS STEEL AISI 316
SSTAINLESS STEEL AISI 304
SGM0106-13

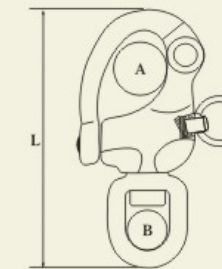

L	A	B
mm	mm	mm
70	12	12
87	16	12
120	22	16

SWIVEL SNAP SHACKLE JAW HEAD

SSTAINLESS STEEL AISI 316
SSTAINLESS STEEL AISI 304
SGM0106-14

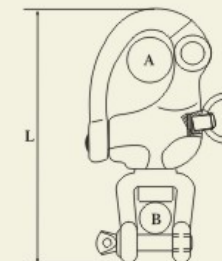

L	A	B
mm	mm	mm
69	12	12
90	16	12
128	22	16

WELDED ROUND RING

STAINLESS STEEL AISI316
STAINLESS STEEL AISI304
STEEL ELECTRIC GALVANIZED
SGM0107

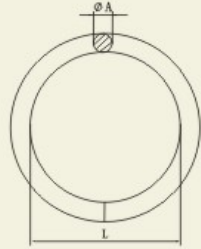

SIZE	ϕA	L
mm	mm	mm
3X25	3	25
4X25	4	25
4X30	4	30
4X40	4	30
5X30	5	30
5X40	5	40
5X50	5	50
6X30	6	30

SIZE	ϕA	L
mm	mm	mm
6X40	6	40
6X50	6	50
6X60	6	60
7X35	7	35
8X40	8	40
8X50	8	50
10X50	10	50
10X70	10	70

D RING

STAINLESS STEEL AISI316
STAINLESS STEEL AISI304
STEEL ELECTRIC GALVANIZED
SGM0108

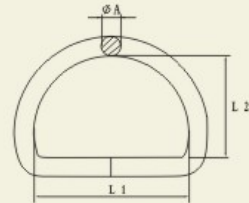

ϕA	L1	L2
mm	mm	mm
3	25	22
4	25	22
4	30	27
5	30	27
5	40	37

ϕA	L1	L2
mm	mm	mm
6	40	37
6	50	47
8	40	37
8	50	47
10	50	47

TRIANGLE RING

STAINLESS STEEL AISI316
STAINLESS STEEL AISI304
STEEL ELECTRIC GALVANIZED
SGM0109

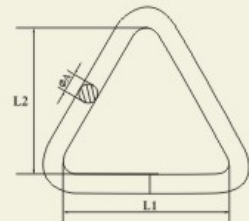

ϕA	L1	L2
mm	mm	mm
5	30	30
6	50	50
8	50	50

TRIANGLE BUCKLE

STAINLESS STEEL AISI316
STAINLESS STEEL AISI304
STEEL ELECTRIC GALVANIZED
SGM0110

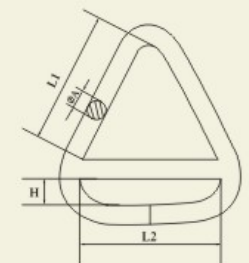

ϕA	L1	L2	H
mm	mm	mm	mm
5	40	45	5.5
6	45	50	7
8	45	50	8

SQUARE HOOK ZINC PLATED

STAINLESS STEEL AISI316
STAINLESS STEEL AISI304
STEEL ELECTRIC GALVANIZED
SGM0111

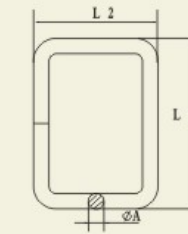

SIZE	ϕA	L1	L2
mm	mm	mm	mm
4	4	40	30

CHAIN CATCH

STAINLESS STEEL AISI316
STAINLESS STEEL AISI304
STEEL ELECTRIC GALVANIZED
SGM0112

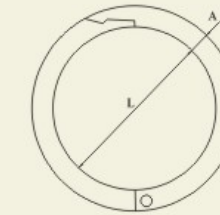

A	L
mm	mm
4	20
5	25
6	30
8	35
9	40

KEY RING

STAINLESS STEEL AISI316
STAINLESS STEEL AISI304
STEEL ELECTRIC GALVANIZED
SGM0113

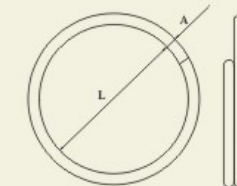

A	L
mm	mm
1.2	20
1.5	25
2	30
2	38

ROLLING-UP PIN WITH ROUND RING

STAINLESS STEEL AISI316
STAINLESS STEEL AISI304
SGM0114

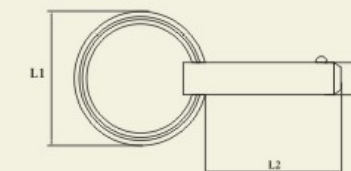

A	L1	L2
mm	mm	mm
M5	25	30
M6	25	30
M8	25	30
M10	38	30

HITCHING RING LAG

STEEL ELECTRIC GALVANIZED
SGM0114-2

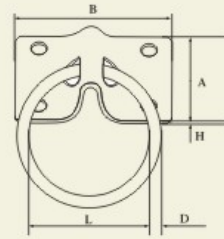

D	A	B	H	L
mm	mm	mm	mm	mm
7	45	70	30	50

"S" HOOK

STAINLESS STEEL AISI316
STAINLESS STEEL AISI304
STEEL ELECTRIC GALVANIZED
SGM0115

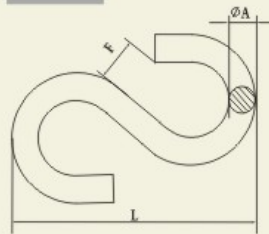

SIZE	Ø A	L	F
mm	mm	mm	mm
3	3	25	3
4	4	35	4.5
5	5	45	6.5
6	6	55	7
7	7	65	8
8	8	75	10
10	10	105	11
12	12	120	13.5

"U" HOOK

STAINLESS STEEL AISI316
STAINLESS STEEL AISI304
STEEL ELECTRIC GALVANIZED
SGM0116

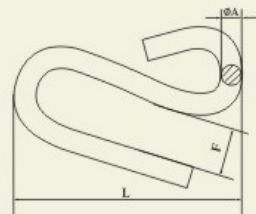

Ø A	L	F
mm	mm	mm
6	55	10.6
8	75	16.5
10	85	19

"S" HOOK

STAINLESS STEEL AISI316
STAINLESS STEEL AISI304
STEEL ELECTRIC GALVANIZED
SGM0117

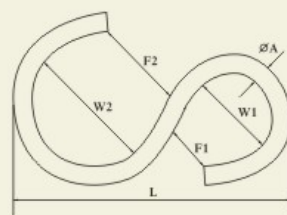

Ø A	L	W1	W2	F1	F2
mm	mm	mm	mm	mm	mm
3	36	9	16	4	11
4	44	12	19	5	11
5	53	14	21	6	11
6	62	15	25	7	16

BUTCHER HOOK

STAINLESS STEEL AISI316
STAINLESS STEEL AISI304
STEEL ELECTRIC GALVANIZED
SGM0119

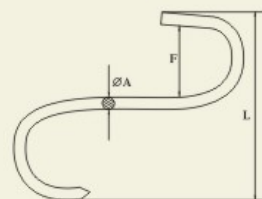

Ø A	L	F
mm	mm	mm
4	80	23
5	100	28
5	120	28

SIMPLE "S" HOOK

STAINLESS STEEL AISI316
STAINLESS STEEL AISI304
STEEL ELECTRIC GALVANIZED
SGM0123

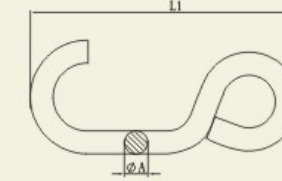

SIZE	Ø A	L1
mm	mm	mm
10	10	120

SWING HOOK WITH BOLT AND PLASTIC WASHER

STAINLESS STEEL AISI316
STAINLESS STEEL AISI304
STEEL ELECTRIC GALVANIZED
SGM0124

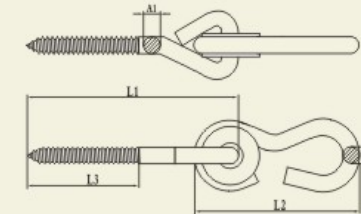

Ø A1	Ø A2	L1	L2	L3
mm	mm	mm	mm	mm
8	7.3	104	76	50

HAMMOCK HOOK WITH WOODEN THREAD

STEEL ELECTRIC GALVANIZED
SGM0124-1

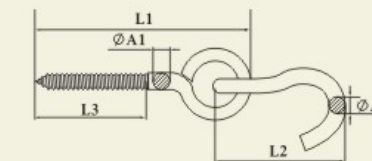

Ø A1	Ø A2	L1	L2	L3
mm	mm	mm	mm	mm
8.4	10	100	90	45
9.5	9.7	100	105	45

TARP ROPE HOOK

STEEL ELECTRIC GALVANIZED
SGM0124-2

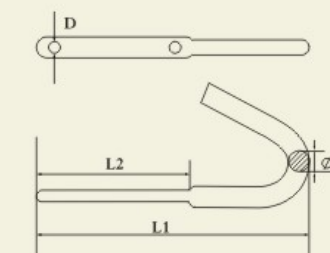

Ø A1	L1	L2	D
mm	mm	mm	mm
10	128	70	8

SWING HOOK WITH BOLT

STAINLESS STEEL AISI316
STAINLESS STEEL AISI304
STEEL ELECTRIC GALVANIZED
SGM0125

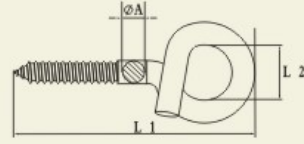

SIZE	∅A	L1	L2
mm	mm	mm	mm
10.6X110	10.6	110	20

SWING HOOK WITH BOLT AND PLASTIC WASHER

STAINLESS STEEL AISI316
STAINLESS STEEL AISI304
STEEL ELECTRIC GALVANIZED
SGM0126

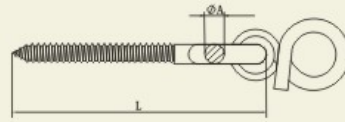

SIZE	∅A	L
mm	mm	mm
10.6X180	10.6	150

SWING HOOK WITH BOLT & 3 NUTS

STAINLESS STEEL AISI316
STAINLESS STEEL AISI304
STEEL ELECTRIC GALVANIZED
SGM0127

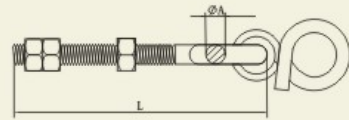

SIZE	∅A	L
mm	mm	mm
10.6X180	10.6	150

EYE SCREW WITH NUT

STAINLESS STEEL AISI316
STAINLESS STEEL AISI304
STEEL ELECTRIC GALVANIZED
SGM0128



MA	L	D
mm	mm	mm
5	75	10
6	75	15
6	100	15
6	150	15
8	100	20

MA	L	D
mm	mm	mm
8	150	20
8	200	20
10	100	25
10	150	25
10	200	25

HOOK BOLT

STAINLESS STEEL AISI316
STAINLESS STEEL AISI304
STEEL ELECTRIC GALVANIZED
SGM0129

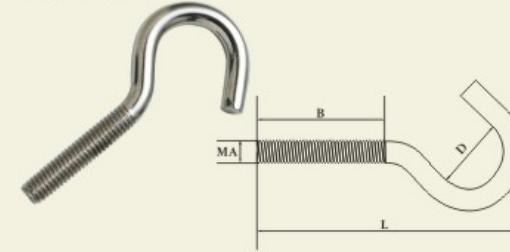

MA	L	B	D
mm	mm	mm	mm
5	40	15	12
5	60	30	12
5	80	50	12
6	60	30	15
6	100	60	15
6	150	80	15

MA	L	B	D
mm	mm	mm	mm
8	80	30	20
8	100	40	20
8	150	80	20
10	100	40	25
10	150	70	25
12	150	70	30

HOOK SCREW

STAINLESS STEEL AISI316
STAINLESS STEEL AISI304
STEEL ELECTRIC GALVANIZED
SGM0130

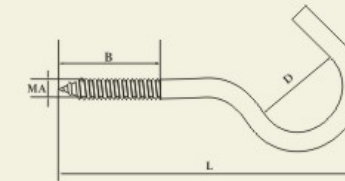

MA	L	B	D
mm	mm	mm	mm
3	40	15	15
4	50	25	15
8	70	30	25

COLLAR HOOK WITH SNAP HOOK

STAINLESS STEEL AISI316
STAINLESS STEEL AISI304
STEEL ELECTRIC GALVANIZED
SGM0131

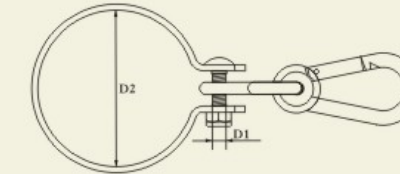

D1	D2
mm	mm
M10	25
M10	50
M10	100
M10	120
M10	140

COLLAR HOOK WITH SWING HOOK

STAINLESS STEEL AISI316
STAINLESS STEEL AISI304
STEEL ELECTRIC GALVANIZED
SGM0132

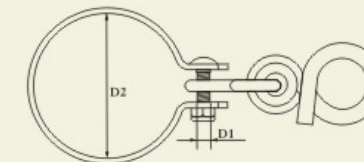

D1	D2
mm	mm
M10	25
M10	50
M10	100
M10	120
M10	140

BIT SNAP TYPE 1

STAINLESS STEEL AISI316
STAINLESS STEEL AISI304
STEEL ELECTRIC GALVANIZED

SGM0133

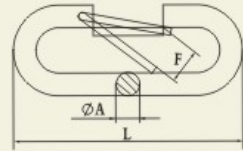

SIZE	∅A	L	F
mm	mm	mm	mm
5	5	45	7
6	6	60	8

BIT SNAP TYPE 2

STAINLESS STEEL AISI316
STAINLESS STEEL AISI304
STEEL ELECTRIC GALVANIZED

SGM0134

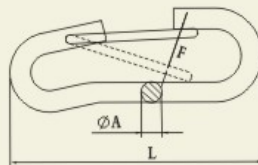

SIZE	∅A	L	F
mm	mm	mm	mm
5	5	60	8

EGG TYPE SNAP HOOK WITH SCREW

STAINLESS STEEL AISI316
STAINLESS STEEL AISI304
STEEL ELECTRIC GALVANIZED

SGM0135

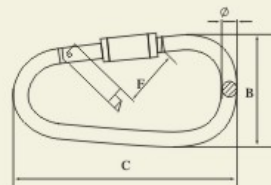

∅A	B	C	F
mm	mm	mm	mm
12	85	168	42

SPRING HOOK

STEEL ELECTRIC GALVANIZED

SGM0135-1

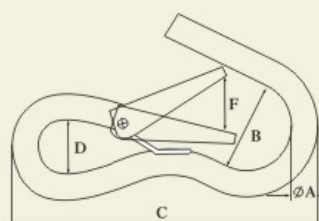

SIZE	A	B	C	D	F
	mm	mm	mm	mm	mm
3/8"	9.5	24	104	13	24.5

SNAP HOOK NO.115D

STEEL ELECTRIC GALVANIZED

SGM0135-2

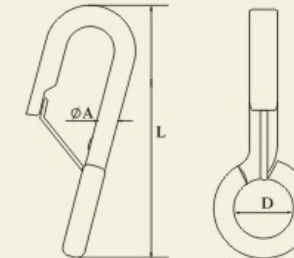

SIZE	∅A	D	L
mm	mm	mm	mm
75X16	6	16	75

SWIVEL SNAP

ZINC PLATED
NICKEL PLATED

SGM0139



SIZE
mm
25
30
40
50
60
70
80
90
100
120

HAIR PIN

ZINC PLATED
NICKEL PLATED

SGM0140

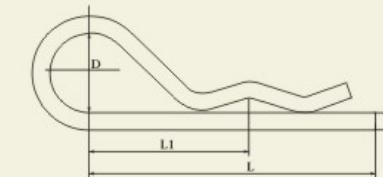

d	L	L1	D
mm	mm	mm	mm
2	50	25	10
3	60	28	18
4	60	30	20
5	85	40	24
6	105	50	30
7	105	50	30
8	110	55	28

HAIR PIN WITH EYELET

ZINC PLATED
NICKEL PLATED

SGM0141

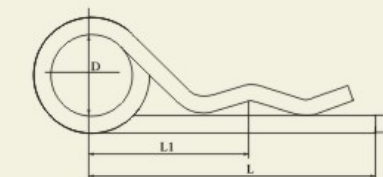

d	L	L1	D
mm	mm	mm	mm
2	50	25	10
3	62	32	16
4	78	44	23
5	92	50	26
6	120	70	30
7	130	72	30
8	130	76	30

LINCH PINS

ZINC PLATED
NICKEL PLATED
SGM0142

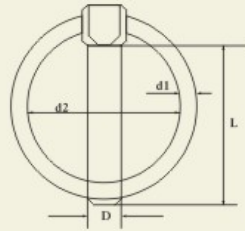

D mm	L mm	d1 mm	d2 mm
4.5	30	2	22
5	40	2.5	24
6	45	3	25
7	45	3	38
8	45	3.5	34
9	46	3.5	34
10	46	3.5	34
11	46	3.5	34

U-BOLT WITH NUT

STAINLESS STEEL AISI316
STAINLESS STEEL AISI304
ZINC PLATED
SGM0146

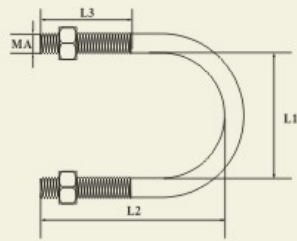

SIZE mm	L1 mm	L2 mm	L3 mm
5	13	30	18
6	17	36	20
6	21	38	22
8	27	48	28
8	34	68	35
8	42	68	35

SLIDE BUCKLE WITH SNAP

ZINC PLATED
NICKEL PLATED
SGM0149



SIZE	THICKNESS mm
1"	2mm

COLD SHUTS

STEEL ELECTRIC GALVANIZED
SGM0149-2

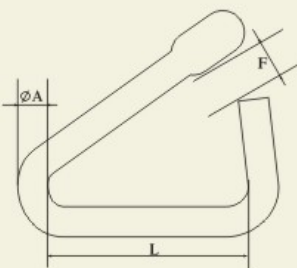

SIZE mm	∅ A mm	L mm	F mm
3/16	5	25	10
1/4	6	30	12
5/16	8	35	12
3/8	9.5	38	14
1/2	12	48	27

QUICK PINS SQUARE TYPE

STEEL ELECTRIC GALVANIZED
SGM0149-3

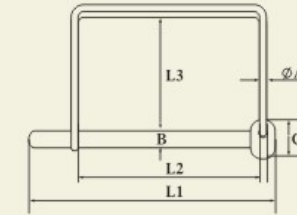

B mm	∅ A mm	L1 mm	L2 mm	L3 mm	C mm
6	2.5	75	60	42	12

CHAIN HOOK

STEEL ELECTRIC GALVANIZED
SGM0149-5

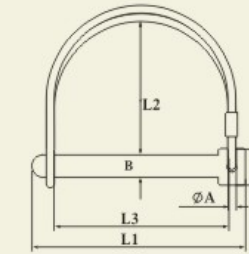

∅ A mm	B mm	C mm	L1 mm	L2 mm	L3 mm
2.5	6	14	60	40	46

ALUMINUM SNAP HOOK D TYPE

SGM0150

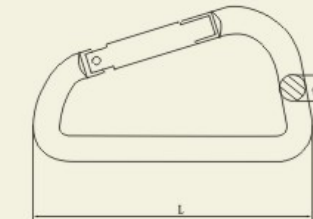

SIZE mm	∅ A mm	L mm
5x50	5	50
6x60	6	60
7x70	7	70
8x80	8	80
10x100	10	100

ALUMINUM SNAP HOOK CARBINE TYPE

SGM0151

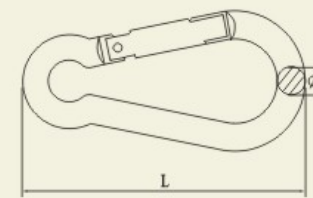

SIZE mm	∅ A mm	L mm
5x50	5	50
6x60	6	60
7x70	7	70
8x80	8	80
10x100	10	100

ALUMINUM SNAP HOOK EGG TYPE

SGM0152

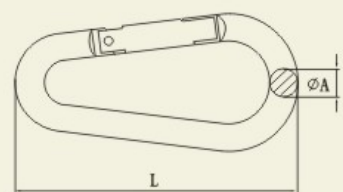

SIZE	Ø A	L
mm	mm	mm
5x50	5	50
6x60	6	60
7x70	7	70
8x80	8	80
10x100	10	100

ALUMINUM SNAP HOOK D TYPE

SGM0157

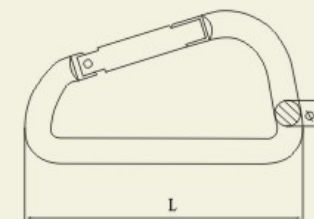

SIZE	Ø A	L
mm	mm	mm
5x50	5	50
6x60	6	60
7x70	7	70
8x80	8	80

ALUMINUM SNAP HOOK D TYPE WITH PIN

SGM0153

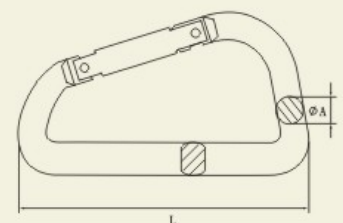

SIZE	Ø A	L
mm	mm	mm
5x50	5	50
6x60	6	60
7x70	7	70
8x80	8	80
10x100	10	100

ALUMINUM SNAP HOOK D TYPE WITH PIN

SGM0158

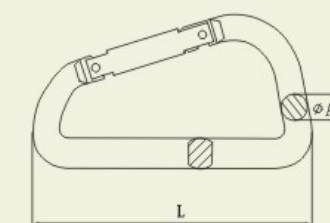

SIZE	Ø A	L
mm	mm	mm
5x50	5	50
6x60	6	60
7x70	7	70
8x80	8	80

ALUMINUM SNAP HOOK WITH EYELET AND KEY RING

SGM0155

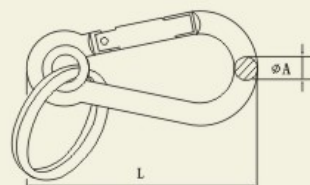

SIZE	Ø A	L
mm	mm	mm
5x50	5	50
6x60	6	60
7x70	7	70
8x80	8	80
10x100	10	100

ALUMINUM SNAP HOOK WITH PVC SPONGE

SGM0159

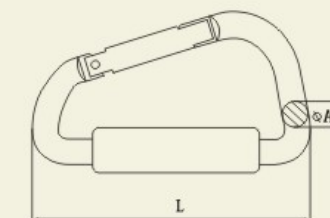

SIZE	Ø A	L
mm	mm	mm
12x160	12	160

ALUMINUM SNAP HOOK CARBINE TYPE

SGM0156

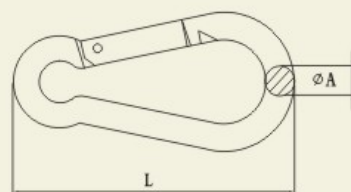

SIZE	Ø A	L
mm	mm	mm
5x50	5	50
6x60	6	60
7x70	7	70
8x80	8	80

ALUMINUM QUICK LINK

SGM0160

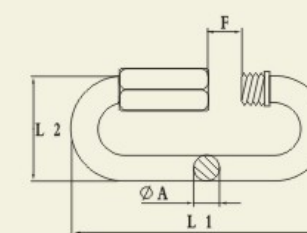

SIZE	Ø A	L1	L2	F
mm	mm	mm	mm	mm
3.5	3.5	36.5	17	5
5	5	49	23	6.5
6	6	58	26.5	7.5
8	8	75	33.5	10.5
9	9	82	35	11.5
10	10	90	40.5	12.5
12	12	107	47.5	14.5

REPAIR LAP LINK

STEEL ELECTRIC GALVANIZED
SGM0166

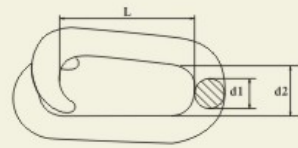

d1 mm	L mm	d2 mm
3	17	7
4	20	8
5	23	10
6	29	11
7	32	14
8	37	15
9	37	16
10	38	17

EYE SLIP HOOKS

ELECTRIC GALVANIZED
H-324 FORGED CARBON STEEL
A-324 FORGED ALLOY STEEL
SGM0167

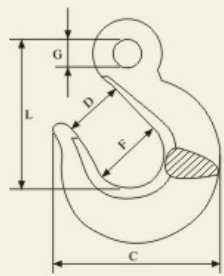

Size in.	Working Load Limit lbs	Weight lbs	Dimensions(in.)					
			C	D	E	F	G	L
1/4	1950	.40	2.75	.94	1.18	3.68	.43	2.56
5/16	2875	.70	2.95	.87	1.26	4.27	.51	2.95
3/8	4000	1.00	3.46	1.29	1.50	4.98	.63	3.35
1/2	6500	2.31	4.84	1.69	1.93	6.40	.75	4.25
5/8	9250	3.78	5.59	2.00	2.38	7.80	.83	5.22

EYE SLIP HOOKS

ELECTRIC GALVANIZED
320C-CARBON STEEL
320A-ALLOY STEEL
SGM0168

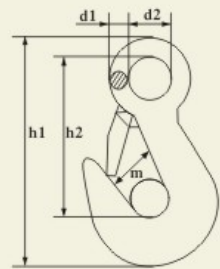

SIZE mm	d1 mm	d2 mm	h1 mm	h2 mm	m mm
8	13	25	146	107	32
10	15	28	160	118	36
12	15	29	162	120	36.5
14	17	32	178	130	40
16	18	35	195	140	44.5
18	19	36	199	145	45

CLEVIS GRAB HOOK 330

G43-CARBON STEEL
G70-ALLOT STEEL
SGM0169

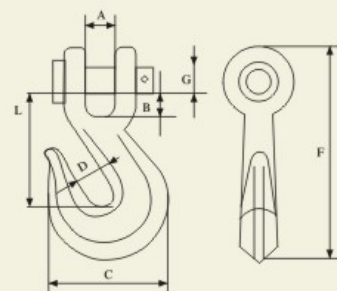

Size of Chain in.	Working Load Limit lbs	Weight lbs	Dimensions(in.)						
			A	B	C	D	F	G	L
1/4	2600	.41	.35	.41	1.92	.53	3.19	.31	1.79
5/16	3900	.63	.39	.43	2.28	.43	3.74	.39	2.13
3/8	5400	1.01	.47	.55	2.66	.51	4.53	.47	2.66
1/2	9200	1.61	.59	.61	3.00	.63	5.31	.63	3.03

SWIVELING ROUND EYE BOLT SNAP

SGM0173

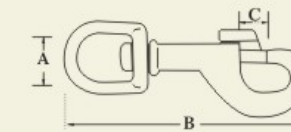
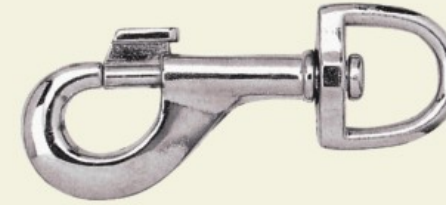

SIZE	A	B	C
5/8"	5/8"	3 1/2"	12mm(1/2")
3/4"	3/4"	3 1/2"	12mm(1/2")
1"	1"	3 5/8"	12mm(1/2")

SWIVELING ROUND EYE BOLT SNAP

SGM0174



SIZE	A	B	C
1"	1"	4"	1/2"(12mm)
1 1/8"	1 1/8"	4 1/8"	1/2"(12mm)
1 1/4"	1 1/4"	4 1/4"	1/2"(12mm)

SWIVEL EYE BOLT SNAP

SGM0175

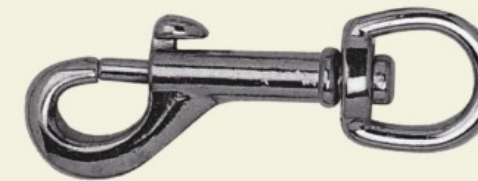

SIZE	A	B	C
3/8"	3/8"	2 1/2"	5/16"(8mm)
1/2"	1/2"	2 5/8"	5/16"(8mm)
3/4"	3/4"	2 5/8"	5/16"(8mm)

SWIVELING STRAP EYE BOLT SNAP

SGM0176



SIZE	A	B	C
5/8"	5/8"	3 1/4"	12mm(1/2")
3/4"	3/4"	3 1/4"	12mm(1/2")
7/8"	7/8"	3 1/4"	12mm(1/2")
1"	1"	3 3/4"	12mm(1/2")
1 1/8"	1 1/8"	3 3/4"	12mm(1/2")
1 1/4"	1 1/4"	3 3/4"	12mm(1/2")

SWIVELING STRAP EYE BOLT SNAP

SGM0177



SIZE	A	B	C
5/8"	5/8"	2 3/4"	3/8"(9mm)
3/4"	3/4"	2 3/4"	3/8"(9mm)

SWIVEL TRIGGER SNAP STRAP EYE

SGM0178



SIZE	A	B	C
5/8"	5/8"	2 1/2"	7/16"(10mm)
3/4"	3/4"	2 1/2"	7/16"(10mm)
1"	1"	2 1/2"	7/16"(10mm)

SWIVEL TRIGGER SNAP STRAP EYE

SGM0179



SIZE	A	B	C
5/8"	5/8"	2 1/2"	7/16"(10mm)
3/4"	3/4"	2 1/2"	7/16"(10mm)
1"	1"	2 1/2"	7/16"(10mm)

SWIVEL TRIGGER SNAP JUMBO TYPE STRAP EYE

SGM0180



SIZE	A	B	C
5/8"	5/8"	3 7/8"	5/8"(14mm)
3/4"	3/4"	3 7/8"	5/8"(14mm)
1"	1"	3 7/8"	5/8"(14mm)
1 1/8"	1 1/8"	3 7/8"	5/8"(14mm)
1 1/4"	1 1/4"	3 7/8"	5/8"(14mm)

SWIVELS

SGM0181



SIZE	A	B
3/4"	3/4"	2"
7/8"	7/8"	2"
1"	1"	2"
1 1/4"	1 1/4"	2"

SWIVELS

SGM0182



SIZE	A	B
3/8"	3/8"	2"
1/2"	1/2"	2 1/4"
5/8"	5/8"	2 1/2"
3/4"	3/4"	2 3/4"
7/8"	7/8"	2 3/4"
1"	1"	3 1/8"

SWIVEL TRIGGER SNAP

SGM0183



SIZE	A	B	C
1/2"	1/2"	2 5/8"	1/2"(13mm)
5/8"	5/8"	2 3/4"	1/2"(13mm)
3/4"	3/4"	2 7/8"	1/2"(13mm)
7/8"	7/8"	2 7/8"	1/2"(13mm)
1"	1"	2 7/8"	1/2"(13mm)

SWIVELING STRAP CAP SNAP

SGM0184



SIZE	A	B	C
5/8"	5/8"	2 1/2"	7/32"(7mm)
3/4"	3/4"	2 1/2"	7/32"(7mm)
1"	1"	2 1/2"	7/32"(7mm)

SWIVELING ROUND CAP SNAP

SGM0185

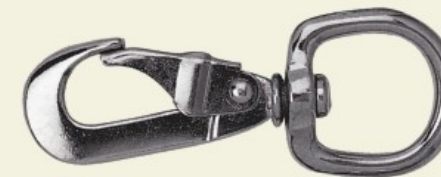

SIZE	A	B	C
5/8"	5/8"	3 3/8"	5/16"(8mm)
3/4"	3/4"	3 1/2"	5/16"(8mm)
1"	1"	3 3/4"	5/16"(8mm)
1"	1"	4"	5/16"(8mm)

SWIVELING STRAP CAP SNAP

SGM0186



SIZE	A	B	C
3/4"	3/4"	3 1/4"	3/8"(9mm)
7/8"	7/8"	3 1/4"	3/8"(9mm)
1"	1"	3 1/4"	3/8"(9mm)
1 1/4"	1 1/4"	3 1/8"	3/8"(9mm)

DOUBLE ENDED BOLT SNAP

SGM0187



SIZE	B	C
3/8"	3 1/2"	3/8"(9mm)
3/8"	4"	3/8"(9mm)
3/8"	4 1/2"	3/8"(9mm)

SPRING SNAP WITH SQUARE STRIP

SGM0188



SIZE	A	B	C
7/8"	7/8"	2 5/8"	7/16" (10mm)
1"	1"	2 3/8"	13/32" (11mm)

SWIVELING ROUND EYE PANIC SNAP

SGM0189

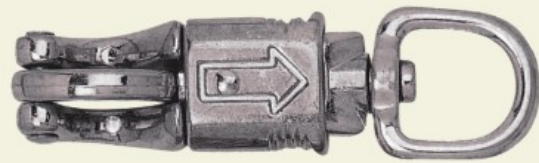

SIZE	A	B
3/4"	3/4"	4 5/8"
1"	1"	4 5/8"

SWIVELING STRAP EYE PANIC SNAP

SGM0190

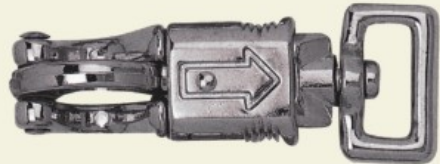

SIZE	A	B
3/4"	3/4"	4"
1"	1"	4"
1 1/4"	1 1/4"	4"

RIGID ROUND EYE PANIC SNAP

SGM0191



SIZE	A	B
1/2"	1/2"	4"

RIGID ROUND EYE PANIC SNAP

SGM0192



SIZE	A	B
	mm	mm
1/2"	12.7	101.6

RIGID STROP EYE SPRING SNAP

SGM0193



SIZE	A	B	C
3/4"	3/4"	2 5/8"	3/8" (9mm)
7/8"	7/8"	3"	3/8" (9mm)
1"	1"	3 1/8"	3/8" (9mm)
1 1/8"	1 1/8"	3 1/8"	3/8" (9mm)
1 1/4"	1 1/4"	3 1/2"	1/2" (12mm)
1 1/2"	1 1/2"	3 1/2"	1/2" (12mm)
1 3/4"	1 3/4"	3 1/2"	1/2" (12mm)
2"	2"	3 3/4"	1/2" (12mm)

RIGID STRAP EYE BOLT SNAP

SGM0194



SIZE	A	B	C
3/4"	3/4"	3 1/8"	3/8" (9mm)
7/8"	7/8"	3 3/8"	13/32" (11mm)
1"	1"	3 3/8"	13/32" (11mm)
1 1/8"	1 1/8"	3 1/2"	7/16" (10mm)
1 1/4"	1 1/4"	3 3/4"	7/16" (10mm)
1 1/2"	1 1/2"	3 7/8"	7/16" (10mm)
2"	2"	3 7/8"	7/16" (10mm)

RIGID ROUND EYE BOLT SNAP

SGM0195



SIZE	A	B	C
1/2"	1/2"	3 3/8"	1 1/32" (8.7mm)
5/8"	5/8"	3 7/8"	1 1/32" (8.7mm)
3/4"	3/4"	3 3/8"	1 1/32" (8.7mm)

SWIVELING STRAP EYE BOLT SNAP

SGM0196

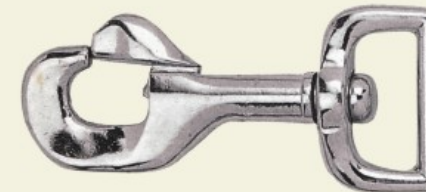

SIZE	A	B	C
3/4"	3/4"	3 1/4"	1/2" (12mm)
7/8"	7/8"	3 1/4"	1/2" (12mm)
1"	1"	3 1/4"	1/2" (12mm)
1 1/4"	1 1/4"	3 1/4"	1/2" (12mm)

SWIVELING ROUND EYE BOLT SNAP

SGM0197

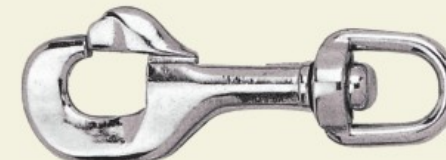

SIZE	A	B	C
	mm	mm	mm
1/2"	12.7	76.2	12.7
5/8"	15.875	76.2	12.7
3/4"	19.05	76.2	12.7
1"	25.4	76.2	12.7

SWIVELING STRAP EYE BOLT SNAP

SGM0198

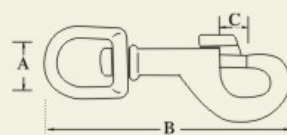
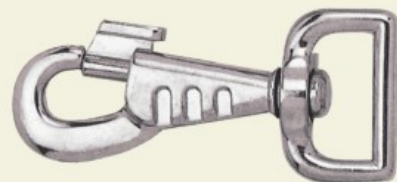

SIZE	A mm	B mm	C mm
3/4"	3/4"	3 3/4"	1/2" (12mm)
7/8"	7/8"	3 3/4"	1/2" (12mm)
1"	1"	3 3/4"	1/2" (12mm)

SWIVELING ROUND EYE BOLT SNAP

SGM0199

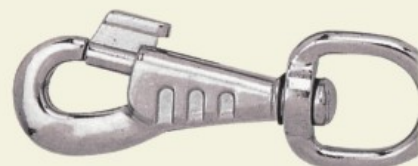

SIZE	A mm	B mm	C mm
5/8"	5/8"	3 3/8"	1/2" (12mm)
3/4"	3/4"	3 1/2"	1/2" (12mm)
1"	1"	3 5/8"	1/2" (12mm)

SNAP HOOK

SGM0200

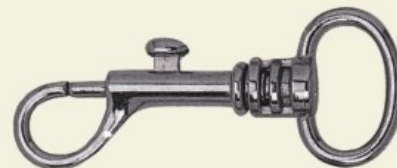

SIZE	A mm	B mm
3/4"	3/4"	2 1/2"

SNAP HOOK

SGM0201



SIZE	A mm	B mm
1/2"	1/2"	1 1/16"
3/4"	3/4"	1 3/4"
1"	1"	1 3/8"
1 1/4"	1 1/4"	1 7/8"

SNAP HOOK RIGID EYE

SGM0202



SIZE	A mm	B mm
7/8"	7/8"	2 1/2"
1"	1"	2 1/2"

SWIVELING SNAP HOOK

SGM0203

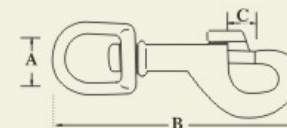

SIZE	A mm	B mm
5/8"	5/8"	1 1/2"

PULLEYS SINGLE WHEEL

SGM0204



SIZE	Diam mm
1/2"	5/32"
3/4"	3/16"
1"	1/4"
1 1/4"	5/16"
1 1/2"	3/8"
2"	7/16"

PULLEYS DOUBLE WHEEL

SGM0205



SIZE	Diam mm
1/2"	5/32"
3/4"	3/16"
1"	1/4"
1 1/2"	5/16"
2"	7/16"

PULLEY SINGLE SHEAVE SWIVEL EYE

SGM0230



SIZE	Diam mm
1/2"	9/32"
3/4"	9/32"
1"	3/8"
1 1/4"	1/2"
1 1/2"	1/2"
2"	1/2"

PULLEY DOUBLE SHEAVE SWIVEL EYE

SGM0231



SIZE	Diam mm
1/2"	9/32"
3/4"	5/16"
1"	3/8"
1 1/4"	1/2"
1 1/2"	1/2"

SNAP HOOK

SGM0206



EYE mm	Length mm
12	47

SNAP HOOK

SGM0207



EYE mm	Length mm
37	54

SWIVEL LOOP SNAP

SGM0232



SIZE	A mm	B mm	C mm
1/2"	1/2"	2"	9 3/2" (7mm)
5/8"	5/8"	3"	3 3/8" (10mm)
3/4"	3/4"	3"	3 3/8" (10mm)
1"	1"	3"	3 3/8" (10mm)

SWIVEL BOLT SNAP

SGM0233



SIZE	A	B	C
3/8"	3/8"	3"	3 3/8" (10mm)
1/2"	1/2"	3"	3 3/8" (10mm)
5/8"	5/8"	3 1/8"	3 3/8" (10mm)
3/4"	3/4"	3 3/8"	3 3/8" (10mm)

SQUARE LOOP BULL SNAP

SGM0234



SIZE	A	B
1"	1"	4"

BULL SNAP

SGM0235



SIZE	A	B
1"	1"	4"

SWIVEL EYE SPRING HOOK

SGM0236



SIZE	A	B
1/2"	1/2"	3 3/8"
5/8"	5/8"	3 3/8"
3/4"	3/4"	3 1/2"

SNAP HOOK RIGID EYE

SGM0237



SIZE mm	B mm
50	50
60	60
70	70
85	85
100	100
120	120

SWIVEL BOLT SNAP

SGM0238



SIZE	A	B
1/2"	1/2"	3 3/8"
5/8"	5/8"	3 3/8"
3/4"	3/4"	3 1/2"
7/8"	7/8"	3 1/2"
1"	1"	3 1/2"

SWIVEL BOLT SNHP

SGM0239



SIZE	A	B	C
3/8"	3/8"	2"	9 3/2" (7mm)

ROPE CLEAT

SGM0240



SIZE	B
2 1/2"	2 1/2"
4 1/2"	4 1/2"
6"	6"

OVAL WIRE ROPE CLIP

SGM0241



SIZE
2mm
3mm
4mm
5mm
6mm

1390 TURNBUCKLE EYE & HOOK

SGM0242

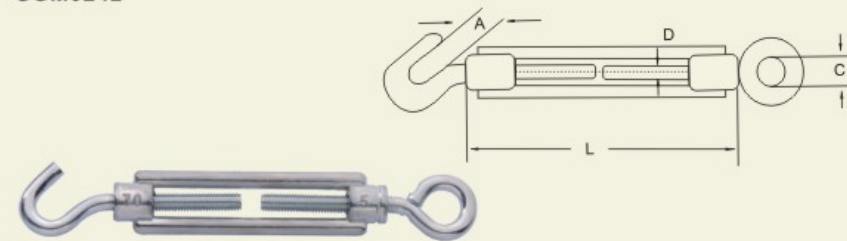

SIZE(D)	L	A	C
	mm	mm	mm
M 5X50	50	7	8
M 5X70	70	7	9
M 6X60	60	8	10
M 6X100	100	10	10
M 8X70	70	11	11
M 8X110	110	11	11
M 10X80	80	11	12
M 10X120	120	16	15
M 12X110	110	15	15
M 12X130	130	15	15

1391 TURNBUCKLE EYE & HOOK

SGM0243

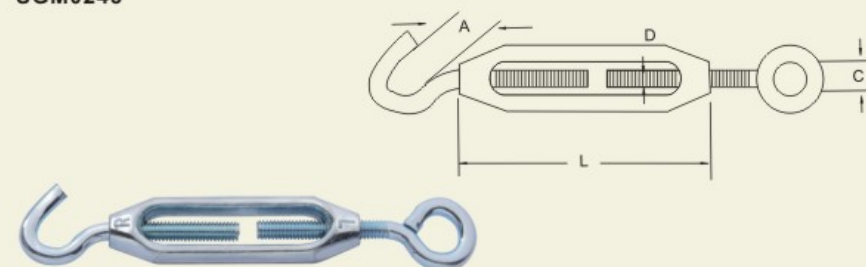

SIZE(D)	L(closed-open)	A	C
3/16"	3 7/8" - 5 1/2"	5/16"	5/16"
7/32"	4 3/8" - 6 1/4"	3/8"	3/8"
1/4"	6 1/2" - 7 3/4"	3/8"	3/8"
5/16"	6 3/4" - 9 3/8"	7/16"	7/16"
3/8"	7 3/4" - 10 1/2"	1/2"	1/2"

251B QUICK SNAP SWIVEL ROUND EYE

BRONZE CASTING
SGM0244

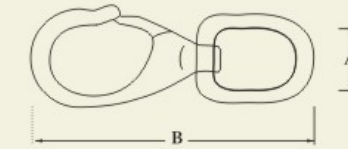

ITEMNO.	SIZE	A	B
251B1	5/8"	5/8"	3 1/4"
251B2	3/4"	3/4"	3 3/8"
251B3	7/8"	7/8"	4 7/8"

225B BOLT SNAP SWIVEL ROUND EYE

BRONZE CASTING
SGM0245



ITEMNO.	SIZE	A	B
225B	5/8"	5/8"	3 1/8"
225B	3/4"	3/4"	3 1/8"
225B	7/8"	7/8"	4"
225B	1"	1"	3 1/2"
225B	1 1/8"	1 1/8"	4 1/2"
225B	1 1/4"	1 1/4"	4 3/4"

227B BOLT SNAP SWIVEL ROUND EYE

BRONZE CASTING
SGM0246



ITEMNO.	SIZE	A	B
227B	3/4"	3/4"	3 3/8"

5025B BOLT SNAP SWIVEL ROUND EYE

BRONZE CASTING
SGM0247



ITEMNO.	SIZE	A	B
5025B	3/8"	3/8"	2 7/8"
5025B	1/2"	1/2"	3"
5025B	5/8"	5/8"	3"
5025B	3/4"	3/4"	3 1/4"

0170B BOLT SNAP SWIVEL STRAP EYE

BRONZE CASTING
SGM0248

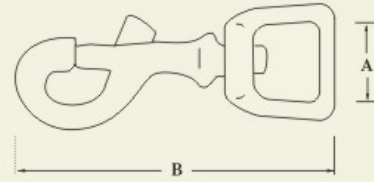

ITEMNO.	SIZE	A	B
017 B	5/8"	5/8"	2 7/8"
017 B	3/4"	3/4"	2 7/8"
017 B	1"	1"	3"
017 B	1 1/4"	1 1/4"	3 1/4"
017 B	1 1/2"	1 1/2"	3 1/4"

0170B BOLT SNAP SWIVEL STRAP ROUND EYE

BRONZE CASTING
SGM0252

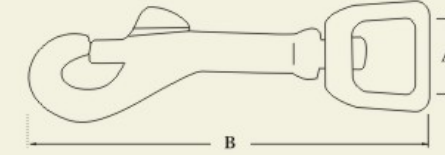

ITEMNO.	SIZE	A	B
0170B	1/2"	1/2"	2 3/4"
0170B	5/8"	5/8"	2 3/4"
0170B	3/4"	3/4"	3"
0170B	1"	1"	3"

830 CAP SNAP SWIVEL ROUND EYE

BRONZE CASTING
SGM0249



ITEMNO.	SIZE	A	B
830B	5/8"	5/8"	3 1/8"
830B	3/4"	3/4"	3 1/2"
830B	1"	1"	3 3/4"

161B BOLT SNAP DOUBLE ENDED

BRONZE CASTING
SGM0253



ITEMNO.	SIZE	A	B
161B	3 1/2"	3 1/2"	3 1/2"
162B	4"	4"	4"
163B	4 1/2"	4 1/2"	4 1/2"

5055B BOLT SNAP SWIVEL ROUND EYE

BRONZE CASTING
SGM02450



ITEMNO.	SIZE	A	B
5055B	3/8"	3/8"	2 1/2"
5055B	1/2"	1/2"	2 1/2"

5015B TRIGGER SNAP SWIVEL STRAP EYE

BRONZE CASTING
SGM0255



ITEMNO.	SIZE	A	B
5015B	5/8"	5/8"	2 5/8"
5015B	3/4"	3/4"	2 5/8"
5015B	1"	1"	2 5/8"

231B BOLT SNAP YIGID OPEN EYE

BRONZE CASTING
SGM0251



ITEMNO.	SIZE	A	B
231B	3 1/2"	3 1/2"	3 1/2"
232B	4"	4"	4"
225B	5"	5"	5"

5013B TRIGGER SNAP SWIVEL ROUND EYE

BRONZE CASTING
SGM0256

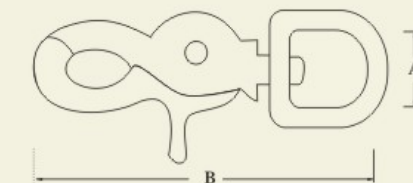

ITEMNO.	SIZE	A	B
5013B	3/8"	3/8"	2 1/2"
5013B	1/2"	1/2"	2 1/2"
5013B	5/8"	5/8"	2 3/4"
5013B	3/4"	3/4"	2 3/4"
5013B	1"	1"	—

350B BOLT SNAP SWIVEL ROUND EYE

BRONZE CASTING
SGM0257



ITEMNO.	SIZE	A	B
350B	3/8"	3/8"	2 1/8"
350B	3/4"	3/4"	2 1/8"
350B	7/8"	7/8"	2 1/8"

25B BOLT SNAP RIGID ROUND EYE

BRONZE CASTING
SGM0258



ITEMNO.	SIZE	A	B
25B	7/8"	7/8"	3 1/4"
25B	1"	1"	3 1/4"
25B	2"	2"	3 1/4"

3726B SPRING SNAP RIGID STRAP EYE

BRONZE CASTING
SGM0259



ITEMNO.	SIZE	A	B
3726B	5/8"	5/8"	2 1/2"
3726B	3/4"	3/4"	2 1/2"
3726B	1"	1"	2 3/4"

249B QUICK SNAP RIGID ROUND EYE

BRONZE CASTING
SGM0260



ITEMNO.	SIZE	A	B
249B0	3/8"	3/8"	2 1/16"
249B1	5/8"	5/8"	2 9/16"
249B2	1 1/16"	1 1/16"	3"
249B3	3/4"	3/4"	3 3/4"

56B SPRING SNAP RIGID STRAP EYE

BRONZE CASTING
SGM0261



ITEMNO.	SIZE	A	B
56B	5/8"	5/8"	2 1/2"
56B	3/4"	3/4"	2 3/8"
56B	1"	1"	2 9/16"

200B SPRING SNAP RIGID STRAP EYE

BRONZE CASTING
SGM0262



ITEMNO.	SIZE	A	B
200B	5/8"	5/8"	2 5/8"
200B	3/4"	3/4"	2 3/4"
200B	1"	1"	3"
200B	1 1/2"	1 1/2"	3"

56BR SPRING SNAP RIGID ROUND EYE

BRONZE CASTING
SGM0264



ITEMNO.	SIZE	A	B
56BR	5/8"	5/8"	2 1/2"
56BR	7/8"	7/8"	2 1/2"

853B CAP DOUBLE ENDED

BRONZE CASTING
SGM0265



ITEMNO.	SIZE	B
853B	3 1/2"	3 1/2"

3142B TIE SNAP SWIVEL ROUND EYE

BRONZE CASTING
SGM0266



ITEMNO.	SIZE	A	B
3142B	7/8"	7/8"	3/4"
3142B	1"	1"	3/8"

2311B SNAP HOOK RIGID ROUND EYE

BRONZE CASTING
SGM0267



ITEMNO.	SIZE	A	B
2311B	3/4"	3/4"	4"
2311B	1 1/8"	1 1/8"	4 3/4"

3002B PANIC HOOK ROUND EYE WITH ROTARY PROTECTION

BRONZE CASTING
SGM0269



ITEMNO.	SIZE	A	B
3002 B	1"	1"	4 1/4"

0178BL PULLEY DOUBLE SHEAVE SWIVEL EYE

BRONZE CASTING
SGM0271



ITEMNO.	SIZE
0178B	3/4"
0178B	1"
0178B	1 1/2"

0176B PULLEY DOUBLE SHEAVE RIGID EYE

BRONZE CASTING
SGM0272



ITEMNO.	SIZE
0176 B	3/4"
0176 B	1"
0176 B	1 1/2"
0176 B	2"

0173B PULLEY SINGLE SHEAVE RIGID EYE

BRONZE CASTING
SGM0273



ITEMNO.	SIZE
0173 B	3/4"
0173 B	1"
0173 B	1 1/4"
0173 B	1 1/2"
0173 B	2"

0174B PULLEY SINGLE SHEAVE RIGID EYE

BRONZE CASTING
SGM0274



ITEMNO.	SIZE
0174 B	3/4"
0174 B	1"
0174 B	1 1/4"
0174 B	1 1/2"
0174 B	2"

26B ROPE CLAMP

BRONZE CASTING
SGM0275



ITEMNO.	SIZE
26B	5/8"
26B	3/4"
26B	7/8"
26B	1"

STEEL WIRE ROPE

6X12+7FC
SGM0208

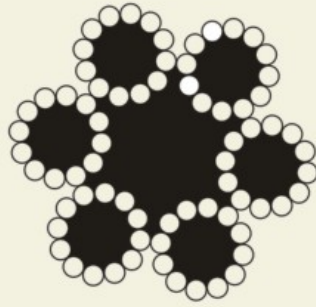

Nominal Diameter (mm)	Approximate Weight (kg/100m)	(N/mm ²) Normal T/S				
		1470	1570	1670	1770	1870
3	2.25	2.70	2.88	3.07	3.25	3.43
4	4.00	4.80	5.12	5.45	5.28	6.10
5	6.3	7.50	8.0	8.5	9.01	9.52
6	9.1	11.08	11.8	12.6	13.3	14.1
7	12.4	13.7	16.0	16.8	17.8	18.8
8	16.2	19.7	21.0	22.4	23.7	25.1
9	20.5	24.5	26.5	27.9	29.5	31.2
10	25.3	30.8	32.8	35.0	37.1	39.2
11	30.6	36.7	39.6	41.7	44.2	46.7
12	36.4	44.3	47.2	50.4	53.3	56.4
14	48.5	59.0	64.2	67.1	71.1	75.1
16	64.8	78.8	83.8	89.6	95.0	100.3
18	82.0	98.1	106.0	111.4	118.0	124.7
20	101.3	123.0	131.0	140.0	148.0	157.0
22	122.5	149.0	159.0	169.0	179.0	190.0
24	145.8	177.0	189.0	201.0	213.0	225.0
26	173.1	210.0	221.0	239.0	253.0	268.0

STEEL WIRE ROPE

6x19+FC
SGM0210

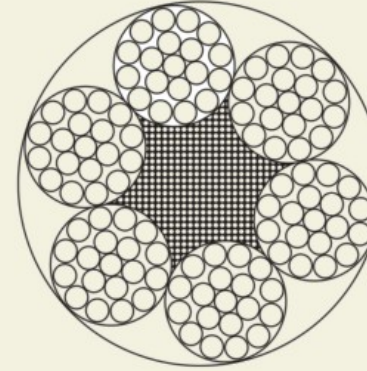

STEEL WIRE ROPE

6x19+IWS
SGM0211

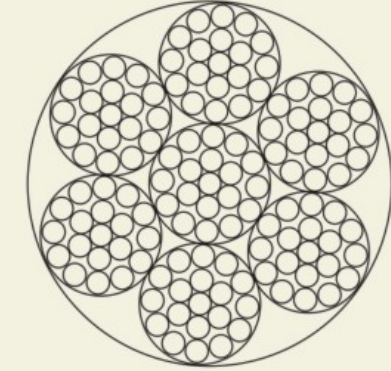

STEEL WIRE ROPE

6X24+7FC
SGM0209

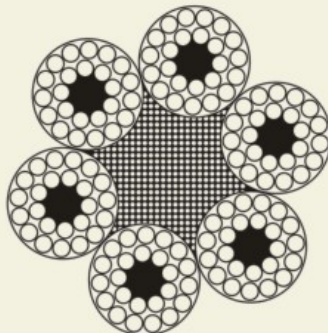

Nominal Diameter (mm)	Approximate Weight (kg/100m)	(N/mm ²) Normal T/S				
		1470	1570	1670	1770	1870
6	11.5	14.8	15.8	16.8	17.8	18.8
8	20.4	26.3	28.1	29.9	31.6	33.4
10	31.8	41.1	43.9	46.7	49.5	52.2
12	45.8	59.2	63.0	67.3	71.2	75.3
14	62.3	80.6	86.1	91.6	97.0	102.5
16	81.4	105.0	112.0	119.0	126.7	133.8
18	103.0	133.0	142.0	151.0	160.0	169.3
20	127.0	164.0	175.0	187.0	198.0	209.0
22	154.0	199.0	212.0	226.0	239.5	253.0
24	183.0	237.0	253.0	269.0	285.0	301.0
26	215.0	278.0	297.0	316.0	334.0	353.3
28	249.0	322.0	344.0	366.0	388.0	410.0
30	286.0	370.0	395.0	420.0	445.0	470.0x
32	326.0	421.0	450.0	478.0	506.0	535.0

Nominal Diameter (mm)	Approximate Weight (kg/100m)		(N/mm ²) Normal T/S									
			1470		1570		1670		1770		1870	
	FC	IWS	FC	IWS	FC	IWS	FC	IWS	FC	IWS	FC	IWS
2	1.38	1.52	1.81	1.95	1.93	2.08	20.5	2.22	2.17	2.35	2.30	2.48
3	3.11	3.43	4.06	4.39	4.33	4.69	4.61	4.98	4.89	5.28	5.16	5.58
4	5.54	6.10	7.22	7.80	7.71	8.33	8.20	8.87	8.69	9.40	9.18	9.93
5	8.65	9.52	11.20	12.20	12.00	13.00	12.80	13.80	13.50	14.60	14.30	15.50
6	12.50	13.70	16.20	17.50	17.30	18.70	18.40	19.90	19.50	21.10	20.60	22.30
7	17.00	18.70	22.10	23.90	23.60	25.50	25.10	27.10	26.60	28.70	28.10	34.40
8	22.10	24.40	28.80	31.20	30.80	33.30	32.80	35.40	34.70	37.60	36.70	39.70
10	34.60	38.10	45.10	48.80	48.10	52.10	51.20	55.40	54.30	58.70	57.40	62.00
12	49.80	54.90	64.90	70.20	69.40	75.00	73.80	79.80	78.20	84.60	82.60	89.40
14	67.80	74.70	88.40	95.60	94.40	102.0	100.0	108.0	106.0	115.0	112.0	121.0
16	88.60	97.50	115.0	124.0	123.0	133.0	131.0	141.0	139.0	150.0	146.0	158.0
18	112.0	123.0	146.0	158.0	156.0	168.0	166.0	179.0	176.0	190.0	186.0	201.0
20	138.0	152.0	180.0	195.0	192.0	208.0	205.0	221.0	217.0	235.0	229.0	248.0
22	167.0	184.0	218.0	236.0	233.0	252.0	248.0	268.0	263.0	284.0	277.0	300.0
24	199.0	219.0	259.0	281.0	277.0	300.0	295.0	319.0	312.0	338.0	330.0	357.0
26	234.0	258.0	305.0	329.0	325.0	352.0	346.0	374.0	367.0	397.0	388.0	419.0
28	271.0	299.0	353.0	382.0	377.0	408.0	401.0	434.0	426.0	460.0	450.0	486.0
30	311.0	343.0	406.0	439.0	433.0	469.0	461.0	498.0	489.0	528.0	516.0	558.0
32	354.0	390.0	462.0	499.0	493.0	533.0	524.0	567.0	556.0	601.0	587.0	635.0
34	400.0	440.0	521.0	564.0	557.0	602.0	592.0	640.0	628.0	679.0	663.0	717.0
36	448.0	494.0	584.0	632.0	624.0	675.0	664.0	718.0	704.0	761.0	744.0	804.0
38	500.0	550.0	651.0	704.0	695.0	752.0	740.0	792.0	784.0	848.0	828.0	896.0
40	554.0	610.0	722.0	780.0	771.0	833.0	820.0	880.0	869.0	940.0	918.0	993.0
42	610.0	672.0	796.0	860.0	850.0	919.0	904.0	978.0	958.0	1030.0	1010.0	1090.0
44	670.0	738.0	873.0	944.0	933.0	1000.0	992.0	1050.0	1030.0	1110.0	1110.0	1200.0
46	732.0	806.0	954.0	1030.0	1010.0	1100.0	1080.0	1140.0	1140.0	1240.0	1210.0	1310.0
48	797.0	878.0	1040.0	1124.0	1110.0	1201.0	1181.0	1277.0	1252.0	1354.0	1322.0	1430.0
50	865.0	952.0	1128.0	1220.0	1205.0	1303.0	1281.0	1386.0	1358.0	1469.0	1435.0	1552.0
52	935.0	1030.0	1220.0	1320.0	1303.0	1409.0	1386.0	1499.0	1469.0	1589.0	1552.0	1678.0
54	1009.0	1111.0	1316.0	1423.0	1405.0	1520.0	1495.0	1616.0	1584.0	1713.0	1672.0	1810.0
56	1085.0	1195.0	1415.0	1530.0	1511.0	1634.0	1607.0	1738.0	1704.0	1842.0	1800.0	1946.0
58	1164.0	1281.0	1518.0	1641.0	1621.0	1753.0	1724.0	1865.0	1828.0	1976.0	1931.0	2088.0
60	1245.0	1371.0	1624.0	1756.0	1735.0	1876.0	1845.0	1996.0	1956.0	2115.0	2066.0	2235.0

STEEL WIRE ROPE

6x37+IWR
SGM0213

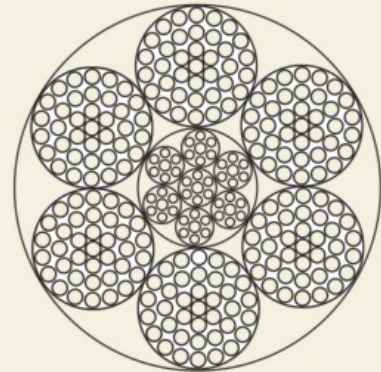

STEEL WIRE ROPE

6x37+FC
SGM0214

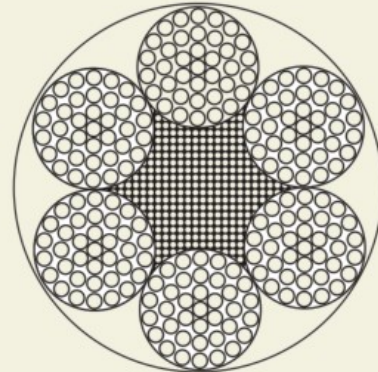

STEEL WIRE ROPE

7X7
SGM0215

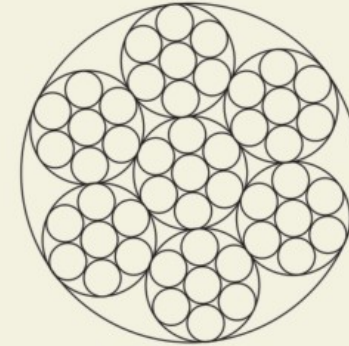

Nominal Diameter	Nominal T/S	(Min. b/1)	Approximate Weight
mm	N/mm	KN	kg/100M
2	1770	2.54	1.55
3	1770	5.71	3.48
4	1770	10.10	6.19
5	1770	15.08	9.68
6	1770	22.08	13.9
7	1770	31.10	19.00
8	1770	40.60	24.80
9	1770	51.40	31.30
10	1770	63.50	38.70
11	1770	76.80	46.80
12	1770	91.5	55.70

Nominal Diameter (mm)	Approximate Weight (kg/100m)		(N/mm) Nominal T/S									
			1470		1570		1670		1770		1870	
			FC	IWR	FC	IWR	FC	IWR	FC	IWR	FC	IWR
5	8.65	9.52	10.80	11.70	11.50	12.50	12.30	13.30	13.0	14.10	13.70	14.90
6	12.50	13.70	15.60	16.80	16.60	18.0	17.70	19.10	18.70	20.30	19.80	21.40
8	22.10	24.40	27.70	30.0	29.60	32.0	31.50	34.0	33.40	36.10	35.30	38.10
10	34.60	38.10	43.40	46.8	46.30	50.0	49.20	53.20	52.20	56.40	55.10	59.60
12	49.80	54.90	62.40	67.50	66.60	72.10	70.90	76.70	75.10	81.30	79.40	85.90
14	67.80	74.70	84.90	91.90	90.70	98.10	96.50	104.0	102.0	110.0	108.0	116.0
16	88.60	94.50	111.0	120.0	118.0	128.0	126.0	136.0	133.0	144.0	141.0	152.0
18	122.0	123.0	140.0	151.0	150.0	162.0	159.0	172.0	169.0	182.0	178.0	193.0
20	138.0	152.0	173.0	187.0	185.0	200.0	197.0	213.0	208.0	225.0	220.0	238.0
22	167.0	184.0	209.0	226.0	224.0	242.0	238.0	257.0	252.0	273.0	266.0	288.0
24	199.0	219.0	249.0	270.0	266.0	288.0	283.0	306.0	300.0	325.0	317.0	343.0
26	234.0	258.0	293.0	316.0	313.0	338.0	333.0	360.0	352.0	381.0	372.0	403.0
28	271.0	299.0	339.0	367.0	363.0	392.0	386.0	417.0	409.0	442.0	432.0	467.0
30	311.0	343.0	390.0	422.0	416.0	450.0	443.0	479.0	469.0	508.0	496.0	536.0
32	354.0	390.0	444.0	480.0	474.0	512.0	504.0	545.0	534.0	578.0	564.0	610.0
34	400.0	440.0	501.0	542.0	535.0	578.0	569.0	615.0	603.0	652.0	637.0	689.0
36	448.0	494.0	562.0	607.0	600.0	649.0	638.0	690.0	676.0	731.0	714.0	773.0
38	500.0	550.0	626.0	677.0	668.0	723.0	711.0	769.0	753.0	815.0	796.0	861.0
40	554.0	610.0	693.0	750.0	741.0	801.0	788.0	852.0	835.0	903.0	882.0	954.0
42	610.0	672.0	764.0	827.0	816.0	883.0	869.0	939.0	921.0	996.0	973.0	1050.0
44	670.0	738.0	839.0	907.0	896.0	969.0	953.0	1030.0	1010.0	1090.0	1060.0	1150.0
46	732.0	806.0	917.0	992.0	980.0	1050.0	1040.0	1120.0	1100.0	1300.0	1160.0	1260.0
48	797.0	878.0	999.0	1080.0	1060.0	1150.0	1130.0	1220.0	1200.0	1410.0	1270.0	1370.0
50	865.0	952.0	1080.0	1170.0	1150.0	1250.0	1230.0	1330.0	1300.0	1520.0	1370.0	1490.0
52	936.0	1030.0	1170.0	1260.0	1250.0	1350.0	1330.0	1440.0	1410.0	1640.0	1490.0	1610.0
54	1010.0	1110.0	1260.0	1360.0	1350.0	1460.0	1430.0	1550.0	1520.0	1770.0	1600.0	1730.0
56	1090.0	1190.0	1350.0	1470.0	1450.0	1570.0	1540.0	1670.0	1630.0	1890.0	1720.0	1870.0
58	1160.0	1280.0	1450.0	1570.0	1550.0	1680.0	1650.0	1790.0	1750.0	2030.0	1850.0	2000.0
60	1250.0	1370.0	1560.0	1680.0	1660.0	1800.0	1770.0	1910.0	1870.0	2170.0	1980.0	2140.0

STEEL WIRE ROPE

6X7+FC
SGM0216

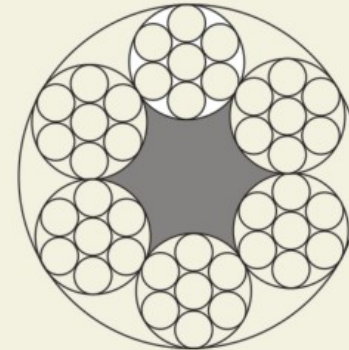

Nominal Diameter	Nominal T/S	(Min. b/1)	Approximate Weight
mm	N/mm	KN	kg/100M
2	1770	2.35	1.40
3	1770	5.28	3.16
4	1770	9.40	5.62
5	1770	14.60	8.77
6	1770	21.10	12.60
7	1770	28.70	17.20
8	1770	37.60	22.50
9	1770	47.50	28.40
10	1770	58.70	35.10
11	1770	71.10	42.50
12	1770	84.60	50.50

DIN763 LINK CHIN

STAINLESS STEEL AISI316
STAINLESS STEEL AISI304
ELECTRIC GALVANIZED

SGM0218

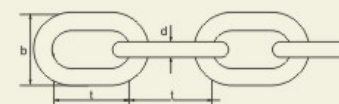

SIZE	INSIDE LENGHT	OUTSIDE WIDTH		WORKING LOAD	TEST LOAD	BREAKING LOAD	WEIGHT PER M		
		b	+MM						
d	t	MM	MM	KG	N	N	KG		
MM	±MM	MM	MM	KG	N	N	KG		
2.0	0.5	22	1.0	8	0.4	25	800	1250	0.06
3.0	0.5	26	1.2	12	0.6	55	1050	3200	0.15
4.0	0.5	32	1.5	16	0.8	100	2500	6500	0.27
5.0	0.5	35	1.8	20	1.0	160	4000	10000	0.43
6	0.5	42	2.0	24	1.2	200	5000	12000	0.63
7	0.5	49	2.5	28	1.4	300	7500	19000	0.86
8	0.5	52	2.5	32	1.6	400	10000	25000	1.10
9	0.5	59	3.0	36	1.8	530	10500	32000	1.41
10	0.5	65	3.2	40	2.0	630	16000	40000	1.75
11	0.5	72	3.4	44	2.0	790	15800	47500	2.11
12	0.5	78	3.6	48	2.3	940	18000	56500	2.55
13	0.5	82	4.0	52	2.5	1000	15000	63000	2.95
16	1	100	5.0	64	3.2	1600	40000	100000	4.45
18	1	113	5.2	70	3.2	2120	42300	127000	5.65
19	1	119	5.6	72	3.4	2370	47300	142000	6.25
20	1	120	6.0	75	3.8	1500	50000	160000	7.00
22	1	127	6.0	82	4.0	3170	63300	190000	8.55
25	1	140	6.6	85	4.2	4090	81700	245000	10.90
28	1	152	7.0	96	4.7	6000	120000	300000	13.9
32	1	171	7.8	108	5.2	8000	160000	400000	18.2

JINRUI HARDWARE RIGGING

DIN766 LINK CHAIN

STAINLESS STEEL AISI316
STAINLESS STEEL AISI304
ELECTRIC GALVANIZED

SGM0219

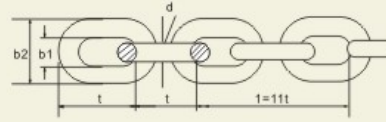

SIZE	INSIDE LENGTH			INSIDE WIDTH b1	OUTSIDE WIDTH b2	LENGTH PER 11 LINKS	WEIGHT PER M
	d	t	t				
2	±MM	MM	+MM -MM	MM	MM	KG N N	KG
2	0.2	12	0.2 0.2	3.5	7.5	132 1.0 0.5	0.07
3	0.2	16	0.2 0.2	4.2	11	176 1.4 0.7	0.16
4	0.2	16	0.3 0.2	5	13.5	176 2.1 1.1	0.32
5	0.2	18.5	0.4 0.2	6	17	203.5 2.4 1.2	0.5
6	0.2	18.5	0.4 0.2	7.2	20.2	203.5 2.4 1.2	0.8
7	0.3	22	0.4 0.2	8.4	23.8	242 3.0 1.4	1.1
8	0.3	24	0.4 0.2	9.6	27.2	264 3.2 1.5	1.4
9	0.4	27	0.5 0.3	10.8	30.6	297 3.6 1.8	1.8
10	0.4	28	0.5 0.3	12	34	308 3.7 1.9	2.2
11	0.4	31	0.5 0.3	13.2	37.8	341 4.0 2.0	2.7
12	0.3	36	0.6 0.3	14.4	40.8	396 4.4 2.2	3.10
13	0.5	36	0.6 0.3	15.6	44.2	396 4.6 2.4	3.8
14	0.6	41	0.7 0.4	16.8	47.6	451 5.4 2.7	4.4
16	0.6	45	0.8 0.4	19.2	54.5	495 6.0 3.0	5.7
18	0.9	50	0.8 0.4	21.6	61.2	550 6.6 3.3	7.3
19	0.4	53	0.9 0.4	22.8	64.6	583 7.0 3.7	7.97
20	1.0	56	1.0 0.5	24.0	68.0	616 7.4 3.7	9.0
22	1.2	62	1.1 0.5	26.4	75.0	682 8.0 4.0	11.0
23	1.2	64	1.1 0.5	27.6	78.2	704 8.4 4.2	12
26	1.3	73	1.2 0.6	31.2	88.4	803 9.6 4.8	15
28	1.4	78	1.3 0.65	33.8	95.2	858 10.2 5.1	18
30	1.5	84	1.4 0.7	41.0	102	924 11.0 5.5	19.5
32	1.6	90	1.5 0.75	43.0	108.8	990 11.8 5.9	23.0

DIN 5685A/C SHORT/LONG LINK CHAIN

ELECTRIC GALVANIZED
HOT DIPPED GALVANIZED

SGM0222

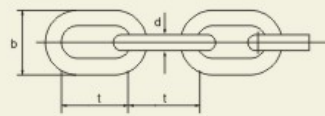

SIZE d	INSIDE LENGTH t	OUTSIDE WIDTH b	WEIGHT PER 100M	TEST LOAD	BREAKING LOAD	TYPE OF LINK
MM	MM	MM	KG	N	N	
2	12	8	7	500	1250	A
	22		6			C
2.5	14	10	11	750	2000	A
	24		10			C
3	16	12	16.5	1120	2800	A
	26		15			C
3.5	18	14	22.5	1500	3850	A
	28		20			C
4	19	16	30	2000	5000	A
	32		27			C
4.5	20	18	39.5	2500	6300	A
	34		35			C
5	21	20	50	3150	7750	A
	35		43			C
5.5	23	22	60.5	3800	9500	A
	38.5		52			C
6	24	24	73	4500	11500	A
	42		63			C
6.5	26	26	86	5400	13500	A
	45.5		74			C
7	28	28	100	6000	15000	A
	49		86			C
8	32	32	130	8000	20000	A
	52		110			C
8.5	34	34	149	9000	22500	A
	56		125			C
9	36	36	165	10000	25000	A
	59		141			C
10	40	40	205	12500	31000	A
	65		175			C
11	44	44	250	15000	38000	A
	72		211			C
12	48	48	290	18000	45000	A
	78		255			C
13	52	52	345	21200	53000	A
	82		295			C

We could supply variety Kinds of skin-packing based on your requirement.

